



# My First Ramadhan Pack



# Legal Disclaimer

© Copyright 2018, UmmAssadHomeSchool.com.

All rights reserved. All materials and content contained on our website and file are the intellectual property of [UmmAssadHomeSchool.com](http://UmmAssadHomeSchool.com) and may not be copied, reproduced, distributed or displayed without our expressed written permission.

No Redistribution. You may not reproduce, repackage, or redistribute the contents of [UmmAssadHomeSchool.com](http://UmmAssadHomeSchool.com) downloads, in whole or in part, for any reason.

No Commercial Use. Downloads may not be used for commercial purposes. Any use of the downloads that infringes upon the intellectual property rights of [UmmAssadHomeSchool.com](http://UmmAssadHomeSchool.com) or that is for commercial purposes will be investigated, and the owner shall have the right to take appropriate civil and criminal legal action.

Modifications of Terms. [UmmAssadHomeSchool.com](http://UmmAssadHomeSchool.com) shall have the right to modify the terms of this agreement at any time. Modification shall be effective immediately and shall replace all prior Agreements.

You MAY:

- Save the files on your computer and print off copies for yourself or classroom.

You MAY NOT:

- Host any [UmmAssadHomeSchool.com](http://UmmAssadHomeSchool.com) files on your own or other sites.
- Alter or sell any [UmmAssadHomeSchool.com](http://UmmAssadHomeSchool.com) files.
- Sell files to make a profit: All files are for personal use only. You may NOT use [UmmAssadHomeSchool.com](http://UmmAssadHomeSchool.com) items for profit. ~ i.e. print them off, laminate them and sell them to others.
- Transmit or store any resources on any other website or other form of electronic retrieval system.
- All downloads are copyright protected. Not to be distributed, transferred, or shared in any form.

If you have any Questions, please Contact us at [UmmAssadHomeSchool@gmail.com](mailto:UmmAssadHomeSchool@gmail.com)

Thank you!

Bismillaahir-Rahmaanir-Raheem.

# Ramadhan pack includes:

1. 5 pillars of Islam
2. Islamic Months
3. Welcoming Ramadhan
4. Ramadhan Checklist
5. 3 Groups of People in Ramadhan
6. Good Deeds in Ramadhan
7. Eid Day

# The 5 Pillars of Islam

The Hadith of Angel Jibreel (peace be upon him) 'Abdullah bin 'Umar said:

"Umar bin Al-Khattab told me: 'While we were with the Messenger of Allah one day, a man appeared before us whose clothes were very white and whose hair was very black. We could see no signs of travel on him, but none of us knew him. He came and sat before the Messenger of Allah ﷺ, putting his knees against his, and placing his hands on his thighs, then he said:

"O Muhammad, tell me about Islam." He said:

"It is to bear witness that there is none worthy of worship except Allah ﷻ and that Muhammad ﷺ is the Messenger of Allah, to establish the Salah, to give Zakah, to fast Ramadan, and to perform Hajj to the House if you are able to bear the journey." He said: "You have spoken the truth." And we were amazed by his asking him, and then saying, "You have spoken the truth".

Grade: Sahih Reference: Sunan an-Nasa'i 4990 In-book reference: Book 47, Hadith 6 English translation: Vol. 6, Book 47, Hadith 4993

Here are the five pillars of Islam.

# 5 Pillars of Islam

Shahadah

Laa ilaaha il Allah,  
Muhammad ar-Rasool Allah

Salaah

Pray minimum 5 times per day

Zakah

Pay Zakah (if able)

Sawm

Fast the month of Ramadhan

Hajj

Perform Hajj to Makkah (if able)

Fasting the Month of Ramadhan is the fourth pillar of Islam!

## Poem time!

Shahadah!

It's to testify...

There's nothing worthy of worship except Allah  
and Muhammad is His Prophet and His Messenger

Salaah!

It's to pray...

All our daily prayers no matter where we are  
Fajr, Thuhr, Asr... Maghrib and Isha

Zakah!

It's to pay the poor...

And needy from our wealth every single year  
Only if we are able to; Allah has made it clear

Sawm!

It's to fast...

In the month of Ramadhan, we do not eat all day  
We do a lot of good deeds like read Quran & pray

Hajj!

It's to make pilgrimage...

We visit the mosque in Makkah if we are able to  
A once in a lifetime experience where we can return  
back new!

Match the pillar to the correct image:

Shahadah



Salaah

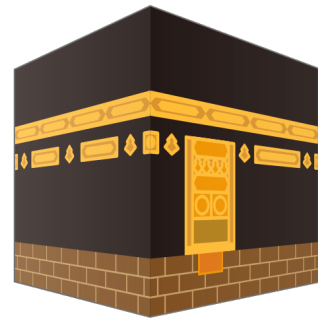

Zakah



Sawm



Hajj

لَا إِلَهَ إِلَّا اللَّهُ

Trace the following words:

Islam

Five Pillars

Shahada

Salaat

Zakat

Sawm

Hajj

Name all the 5 pillars of Islam:

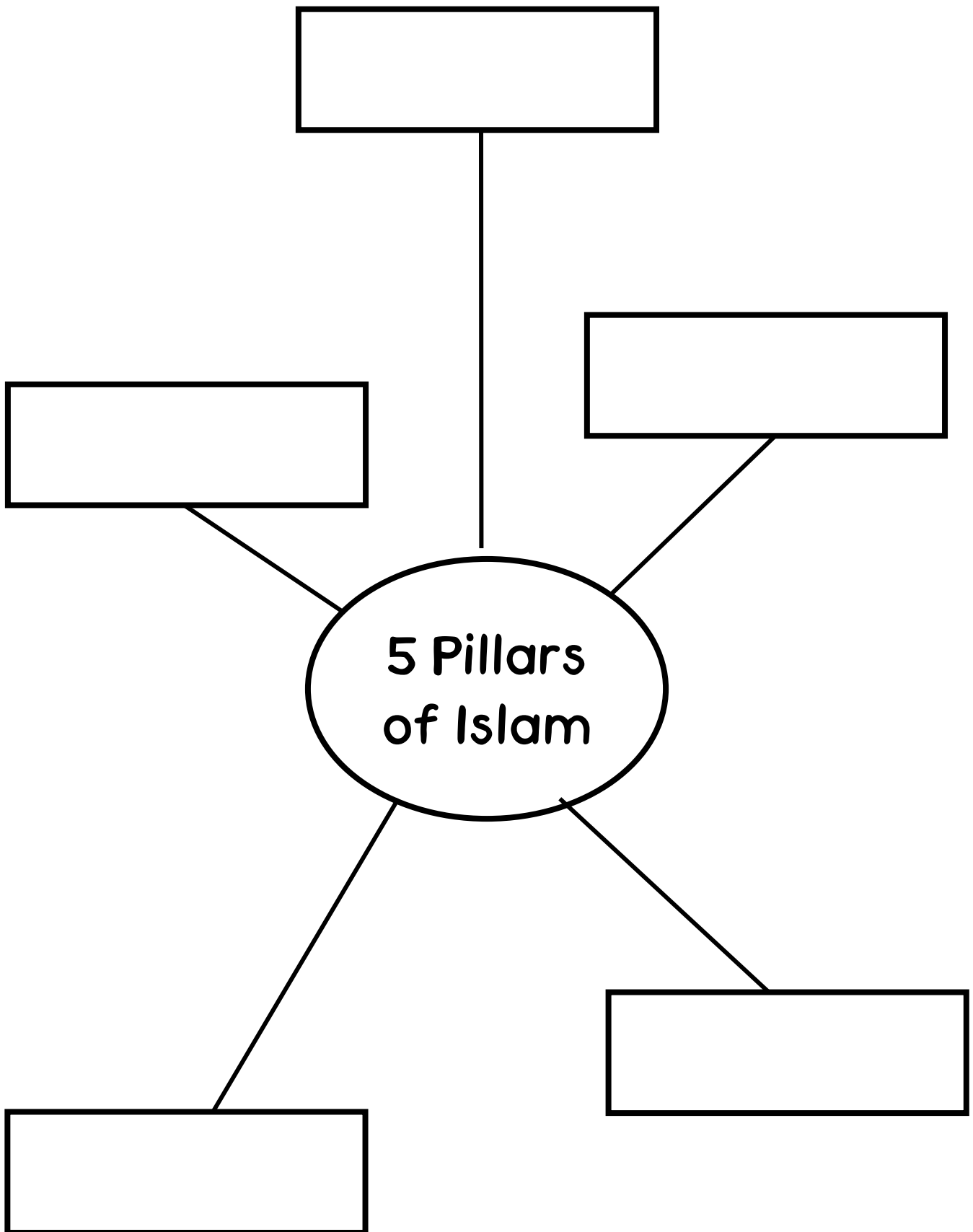

Name all the 5 pillars of Islam in order:

**1.**

---

**2.**

---

**3.**

---

**4.**

---

**5.**

---

# The Month of Ramadhan

Ramadhan is the ninth month in the Islamic calendar. It consists of 30 days, maybe 29 (depending on the sighting of the moon).

Islamic Months:
Muharram
Safar
Rabi' al-Awwal
Rabi' ath-Thaani
Jumaad-al-Oola
Jumad-al-Akhirah
Rajab
Sha'ban
<b>Ramadhan</b>
Shawwaal
Dhul-Qa'adah
Dhul-Hijjah

# Ramadhan



Ramadhan

Ramadhan

Ramadhan

# Welcoming Ramadhan

Shaykh Salih Al-Fawzan said:

It is befitting that a Muslim greets this month with happiness, delight, joy, praising Allah and seeking Allah's help to fast and do good deeds.

## How do we verify when Ramadhan begins?

1. Sighting the moon
2. Check if it is cloudy

Allah The Exalted said:

"The month of Ramadân in which was revealed the Qur'ân, a guidance for mankind and clear proofs for the guidance and the criterion (between right and wrong). So whoever of you sights (the crescent on the first night of) the month (of Ramadân i.e. is present at his home), he must observe Saum (fasts) that month, and whoever is ill or on a journey, the same number [of days which one did not observe Saum (fasts) must be made up] from other days. Allâh intends for you ease, and He does not want to make things difficult for you. (He wants that you) must complete the same number (of days), and that you must magnify Allâh [i.e. to say Takbîr (Allâhu-Akbar; Allâh is the Most Great) for having guided you so that you may be grateful to Him."

*(Quran: Surah 2, Ayah 185 – Translated by Muhsin Khan)*

and,

"They ask you (O Muhammad) about the new moons. Say: These are signs to mark fixed periods of time for mankind and for the pilgrimage."

*(Quran: Surah 2, Ayah 189 – Translated by Muhsin Khan)*

The Prophet sallallahu alaihi wa sallam said:

"When you see the new moon, then fast, and when you see it, break your fast: and if it is cloudy, complete the month."

*(Hadith: Reported by Al-Bukhari and Muslim)*

There are 8 Moon Phases:

1. New Moon
2. Waxing Crescent
3. First Quarter
4. Waxing Gibbous
5. Full Moon
6. Waning Gibbous
7. Last Quarter
8. Waning Crescent

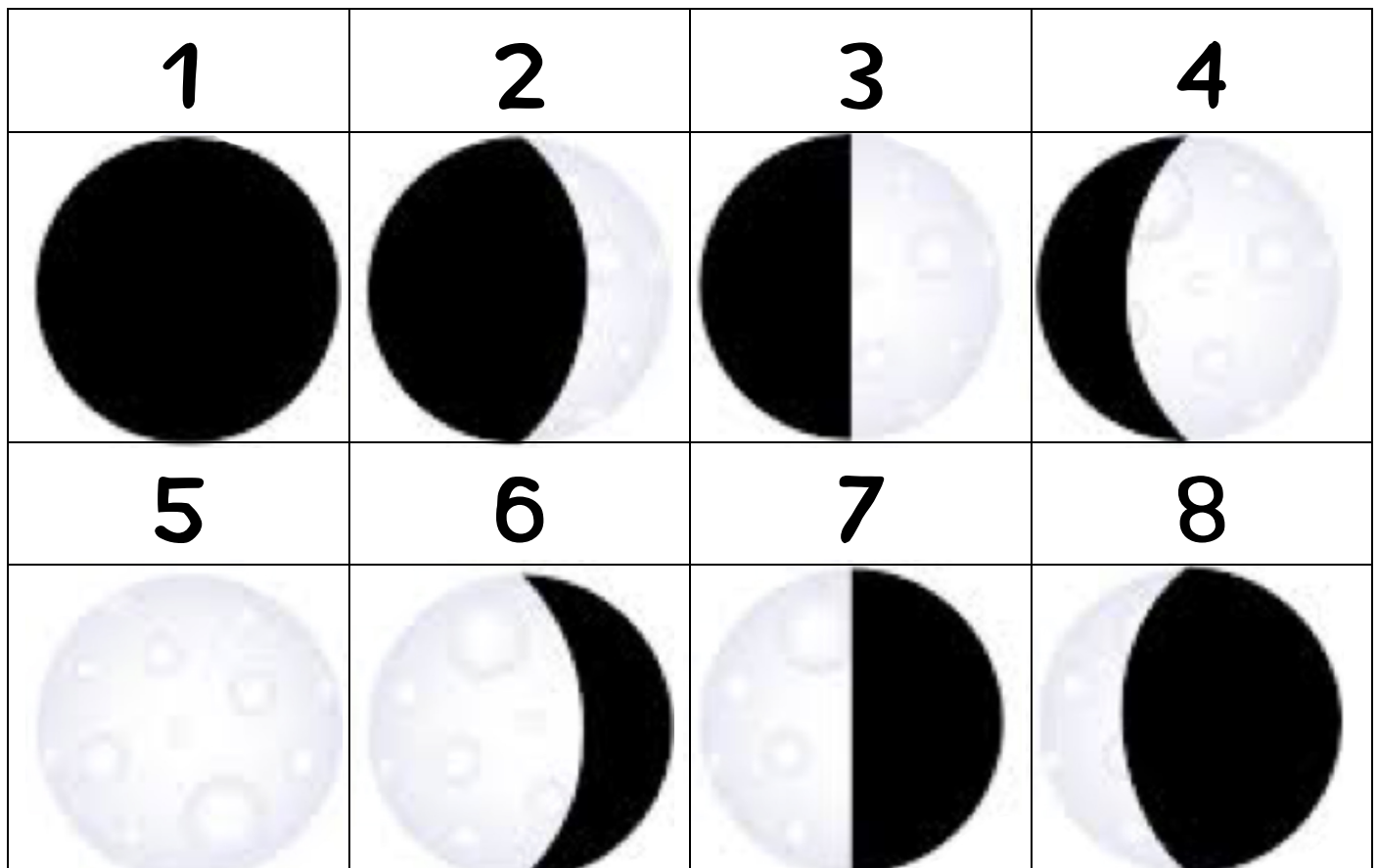

Cut out the following wheels and connect them with a snap button or split pin:



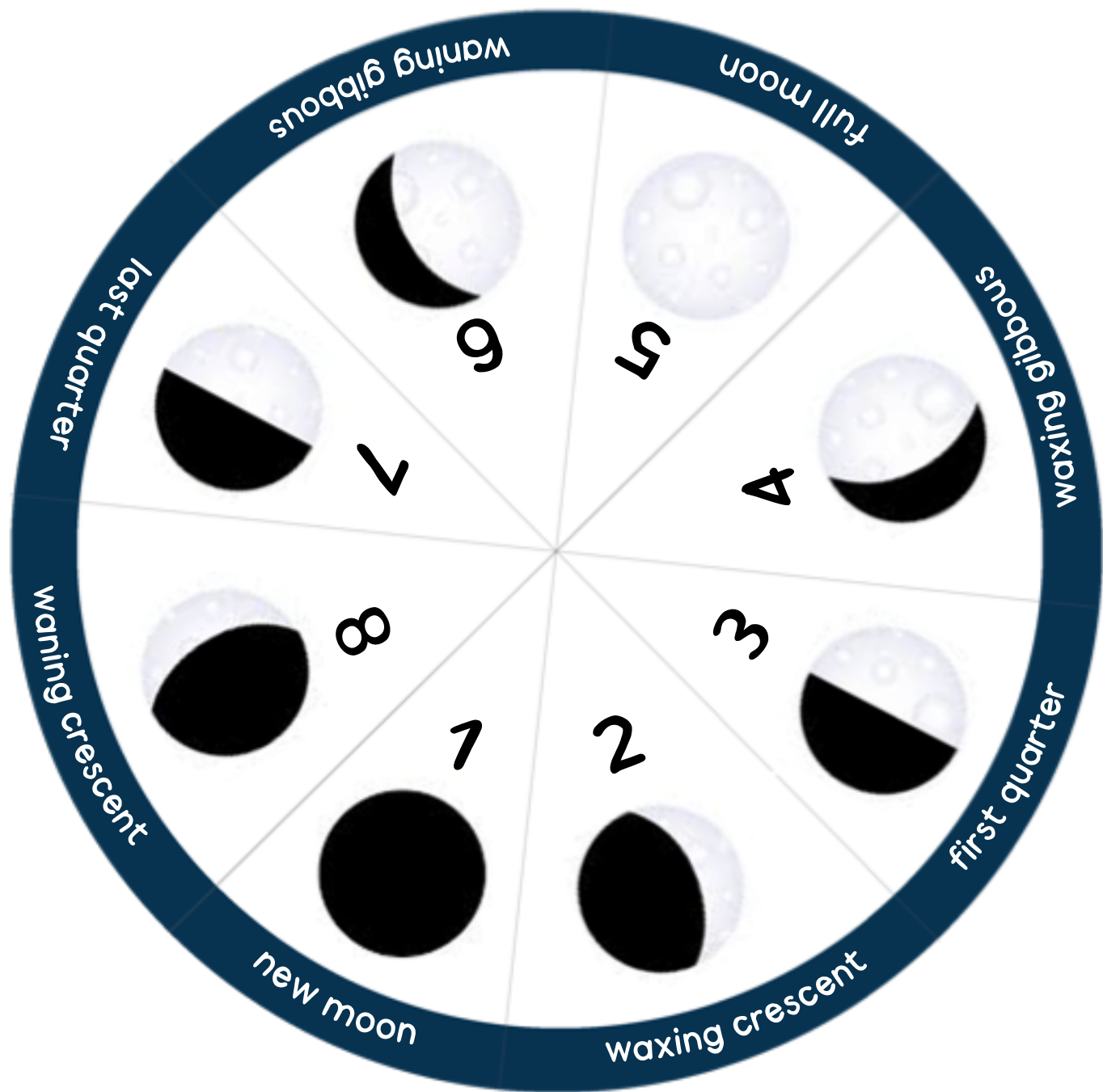

Colour in the following picture:

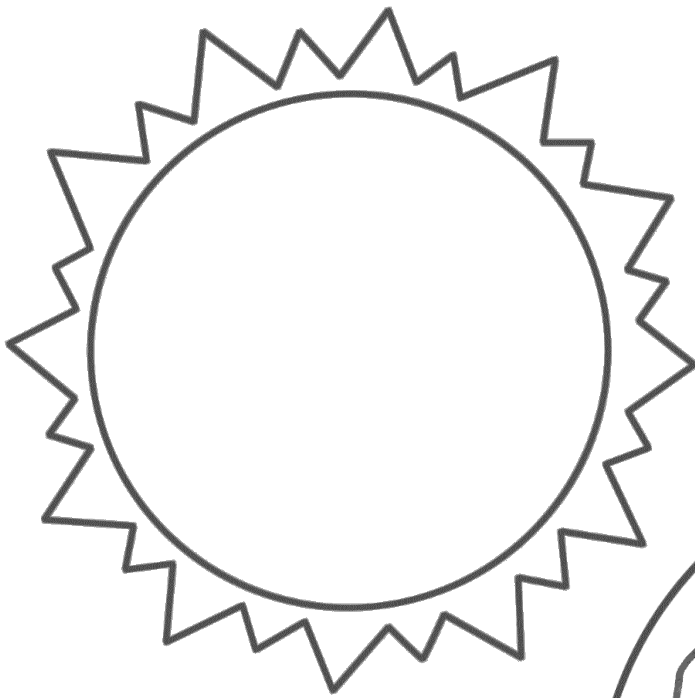

- u n

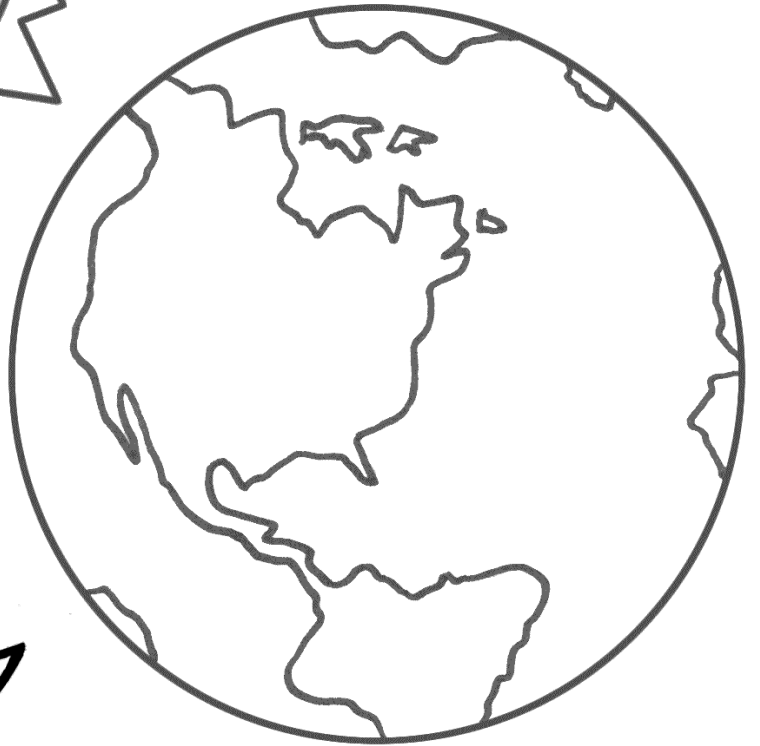

- o o n

- t a r s

# Find the following words in this Moon Phase

## Wordsearch:

New Moon

First Quarter

Full Moon

Last Quarter

Waxing Crescent

Waxing Gibbous

Waning Gibbous

Waning Crescent

D	R	E	T	R	A	U	Q	T	S	R	I	F	S	C
S	A	J	D	T	Q	W	C	U	Q	W	B	H	L	T
U	K	R	F	X	U	A	Y	K	C	Z	M	X	A	E
O	G	C	O	G	F	X	O	C	R	O	S	E	V	D
B	I	P	Q	T	K	I	J	F	T	R	Q	P	E	D
B	K	D	L	P	Q	N	D	Z	Y	Y	U	I	T	V
I	W	A	N	I	N	G	C	R	E	S	C	E	N	T
G	Q	H	U	N	J	C	L	X	L	G	K	K	N	T
G	L	A	L	E	A	R	S	B	P	B	Q	Z	O	A
N	P	B	P	W	L	E	S	M	G	B	U	I	P	Y
I	H	F	W	M	A	S	N	O	O	M	L	L	U	F
N	Y	P	R	O	V	C	Y	V	O	M	X	S	X	Y
A	B	R	Q	O	U	E	J	T	Y	D	Q	S	B	N
W	O	J	A	N	R	N	S	F	L	P	Y	W	I	E
D	H	J	L	I	L	T	A	O	E	T	K	M	T	Y

# Ramadhan Checklist

Deed	MADE WUDHU	PRAY	QURAN	DUA	DHIKR	SEEK 'ILM	CHARITY	OTHER GOOD DEED
Day								
1								
2								
3								
4								
5								
6								
7								
8								
9								
10								
11								
12								
13								
14								
15								
16								
17								
18								
19								
20								
21								
22								
23								
24								
25								
26								
27								
28								
29								
30								

## There are 3 groups of people in Ramadhan.

Shaykh 'Ab al-Razzaq Ibn 'Abd al-Muhsin al-'Abbad said:

"One group of people meet this month by focusing on the market places so they can buy different types of foods...they buy more food than normal...wasting stunning amounts.

Another group of people prepare for themselves different forms of games, amusements and distractions...wasting their time with things which are of no benefit.

There is another group of people whom Allah has graced with success...they prepare themselves for Ramadhan. You find they have plenty of ideas to do good starting by allocating time for Quran, remembrance of Allah, time for praying night prayer, assisting the poor, time for spending, and attending circles of knowledge."

Name some good deeds that you can do during the month of Ramadhan:

<hr/>	<hr/>
<hr/>	<hr/>
<hr/>	<hr/>
<hr/>	<hr/>
<hr/>	<hr/>
<hr/>	<hr/>
<hr/>	<hr/>
<hr/>	<hr/>
<hr/>	<hr/>
<hr/>	<hr/>

Fasting; Add your favourite food to the plate and colour it in:

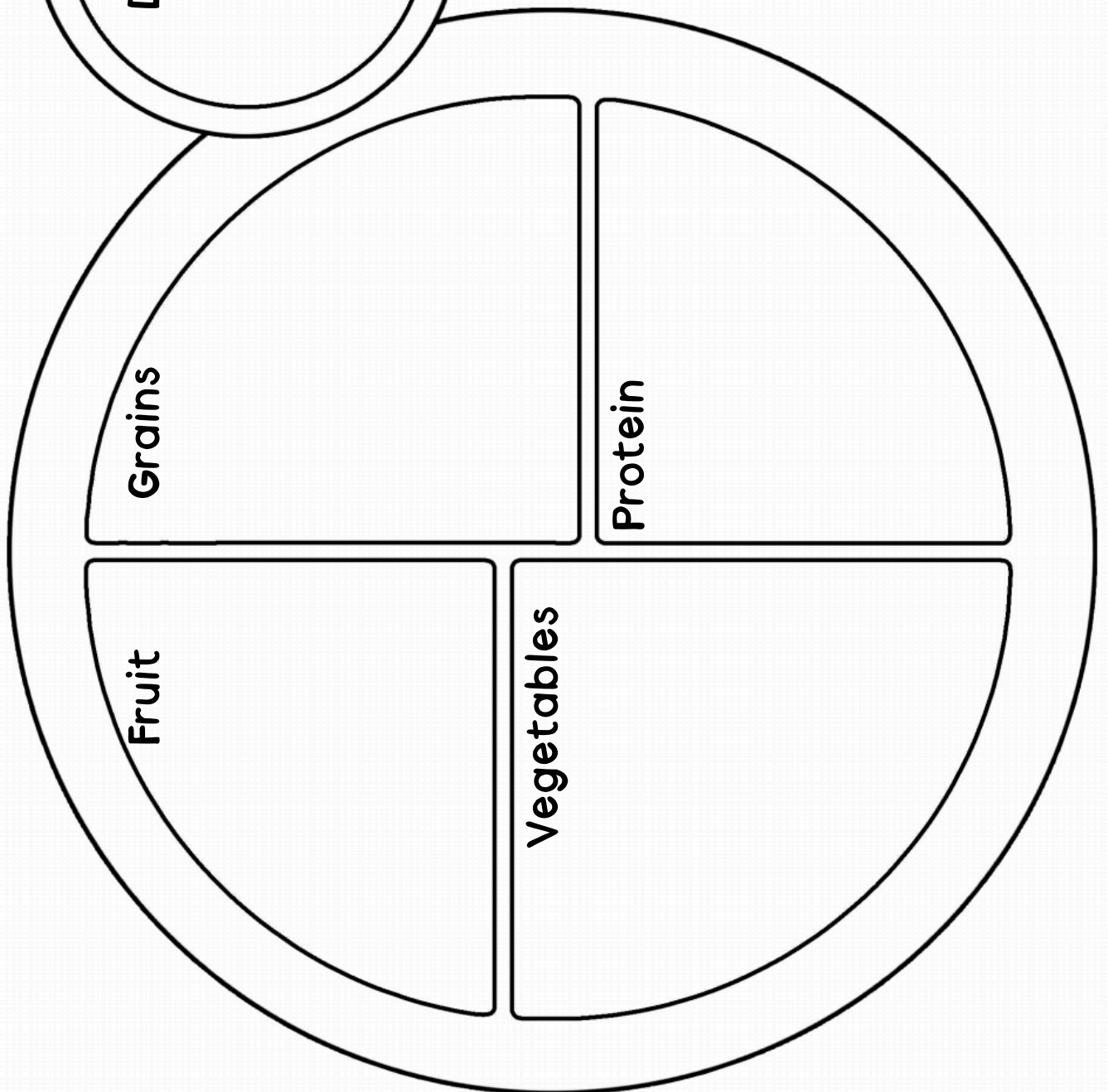
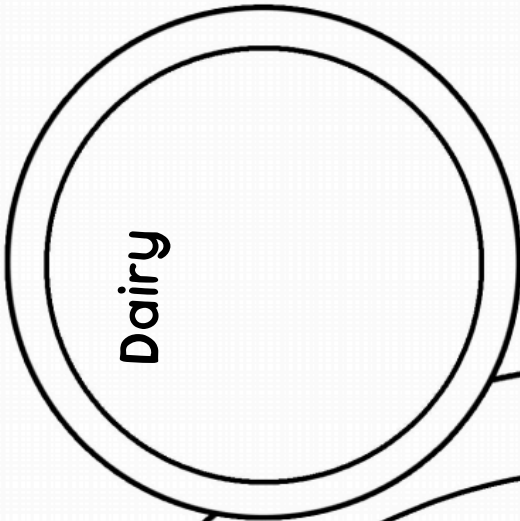

# Night prayer and Dua for Laylatul-Qadr; Colour in:

O Allaah; You are The One Who pardons greatly; and You love to pardon; so pardon me.

Reported by At-Tirmidhee (no.3513) and Ibn Maajah (no.3850) and Ahmad (no.25384) and others and was declared *saheeh* (authentic) by Shaikh Al-Albaanee in his *Saheeh Sunan At-Tirmidhee* (no.3513).

اللَّهُمَّ إِنَّكَ عَفُوفٌ عَفِيفٌ تَجِيبُ الْعَفْوَ فَاعْفُ عَنِّي

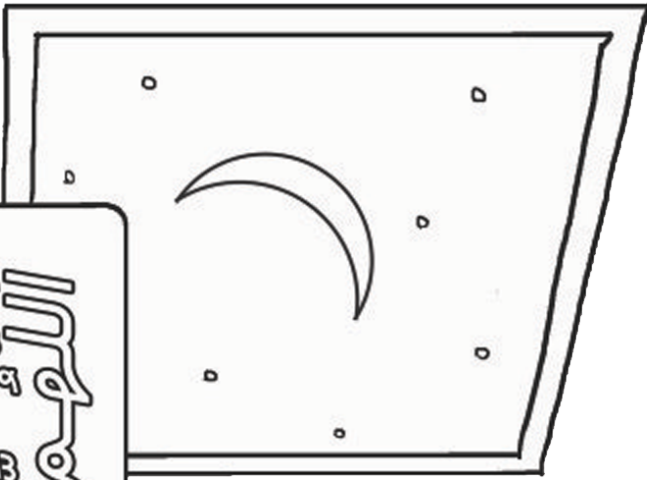

- r a y

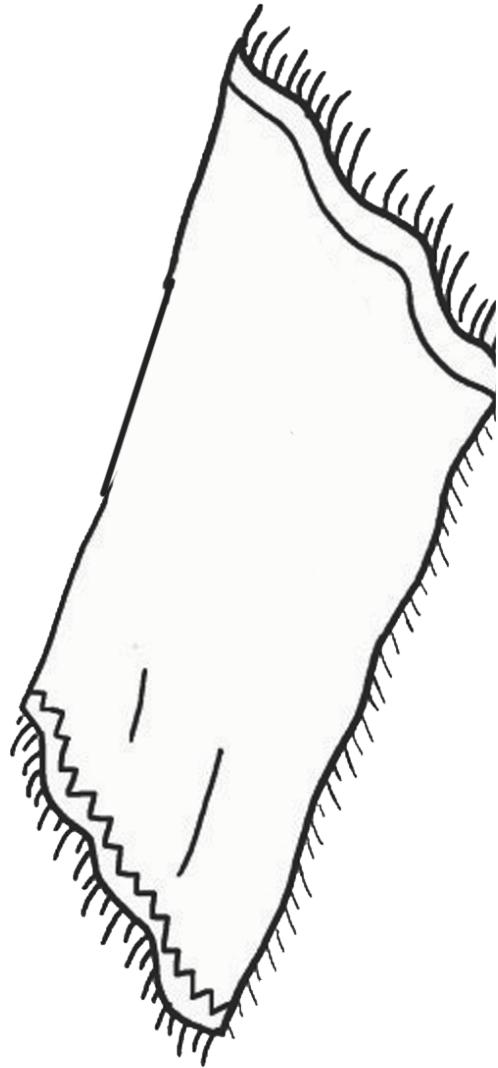

- a t

## Reciting Quran:

### Surah Qadr:

In the name of Allah, the Beneficent, the Merciful

Verily, We have sent it (this Qur'ân) down in the night of Al-Qadr (Decree)(1) And what will make you know what the night of Al-Qadr (Decree) is? (2) The night of Al-Qadr (Decree) is better than a thousand months (i.e. worshipping Allâh in that night is better than worshipping Him a thousand months, i.e. 83 years and 4 months) (3) Therein descend the angels and the Rûh [Jibril (Gabriel)] by Allâh's Permission with all Decrees, (4) (All that night), there is Peace (and Goodness from Allâh to His believing slaves) until the appearance of dawn. (5)

*Translated by Muhsin Khan.*

## سُورَةُ الْقَدْرِ

بِسْمِ اللَّهِ الرَّحْمَنِ الرَّحِيمِ

- إِنَّا أَنْزَلْنَاهُ فِي لَيْلَةِ الْقَدْرِ (١)  
وَمَا أَدْرَاكَ مَا لَيْلَةُ الْقَدْرِ (٢)  
لَيْلَةُ الْقَدْرِ خَيْرٌ مِّنْ أَلْفِ شَهْرٍ (٣)  
تَنَزَّلُ الْمَلَائِكَةُ وَالرُّوحُ فِيهَا بِإِذْنِ رَبِّهِمْ مِّنْ كُلِّ أَمْرٍ (٤)  
سَلَامٌ هِيَ حَتَّىٰ مَطْلَعِ الْفَجْرِ (٥)

Colour in:

\_ u r a n

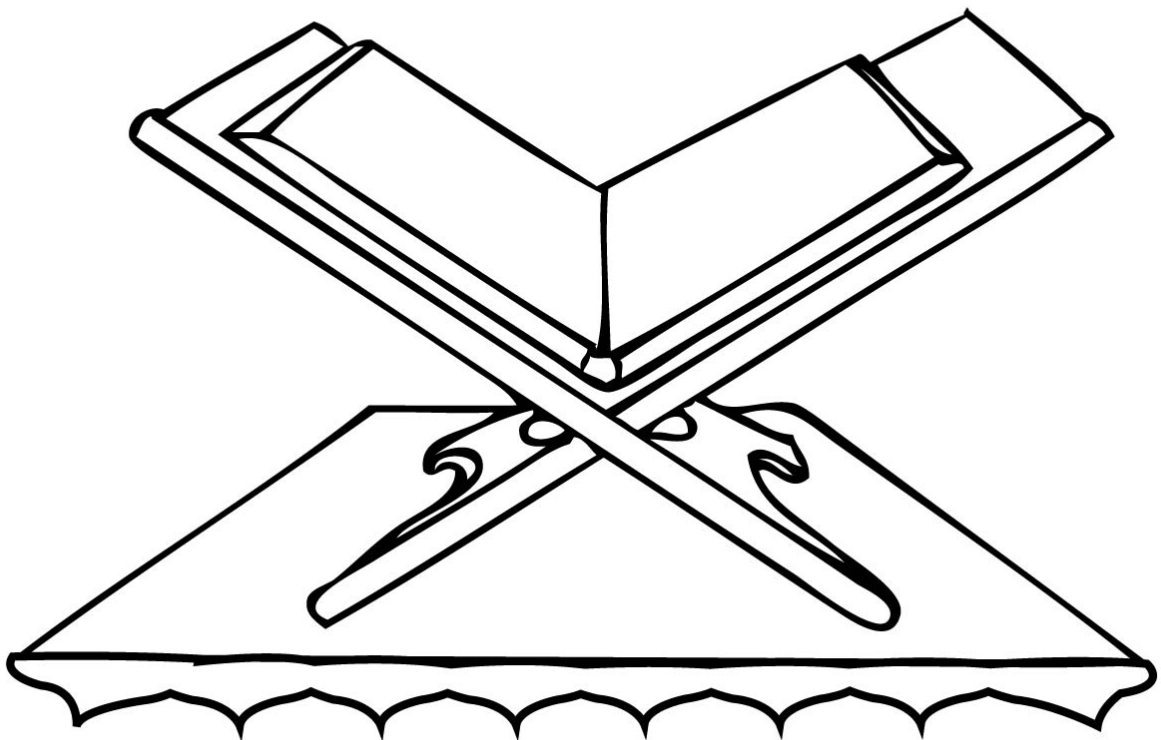
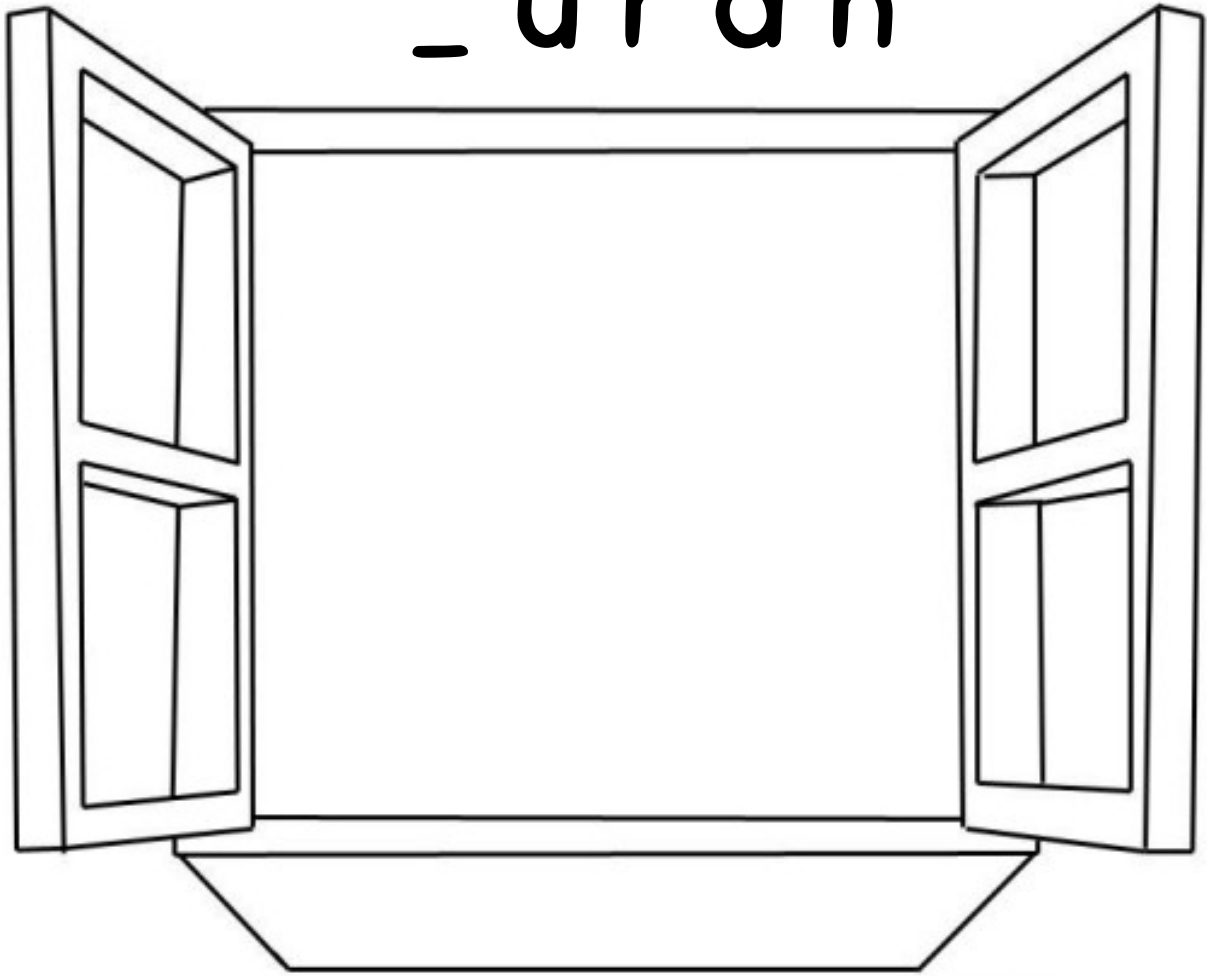

Giving charity; colour in:

\_ o n e y



Charity Box; use card, decorate, cut out and glue:

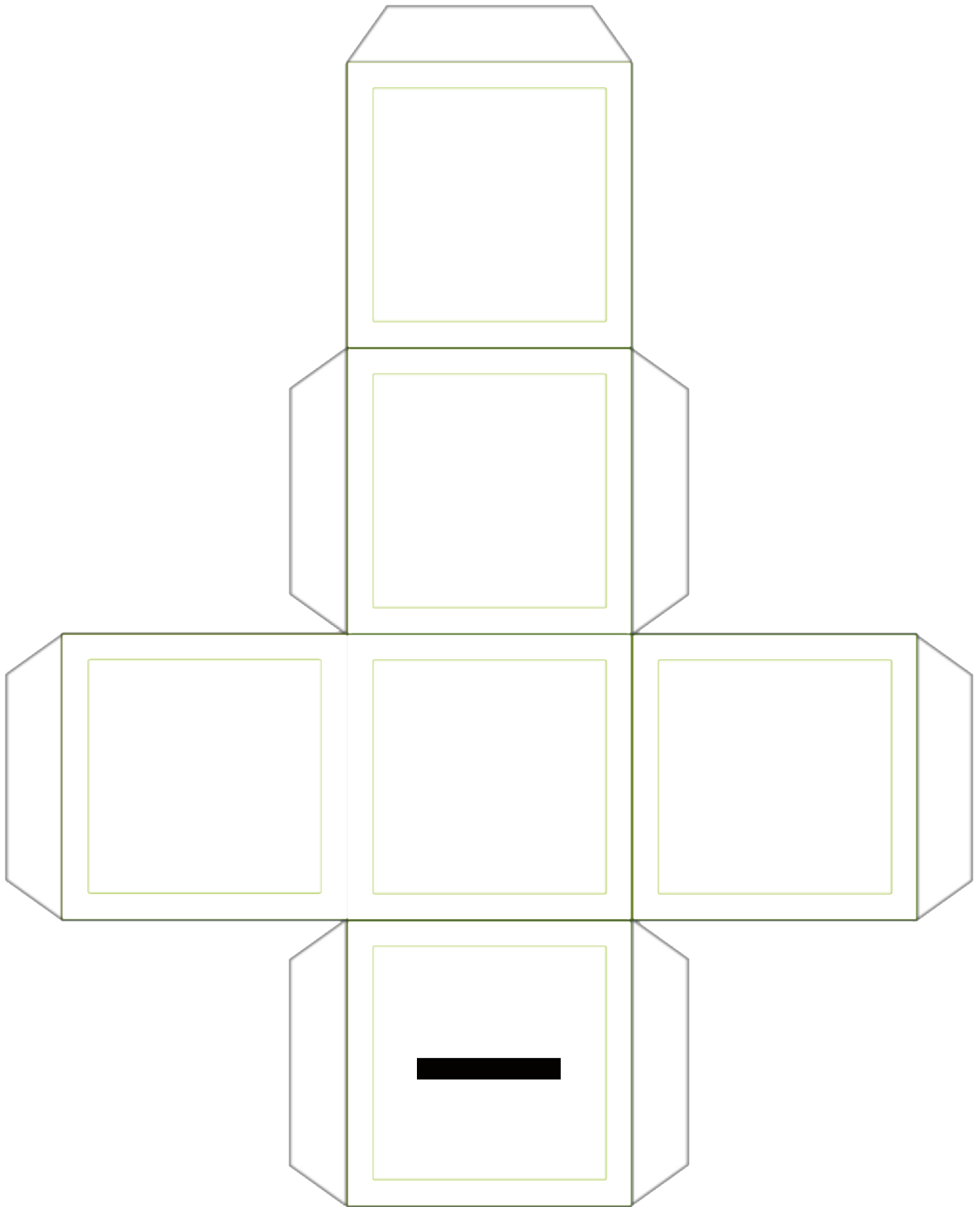

Going to the Masjid; colour in:

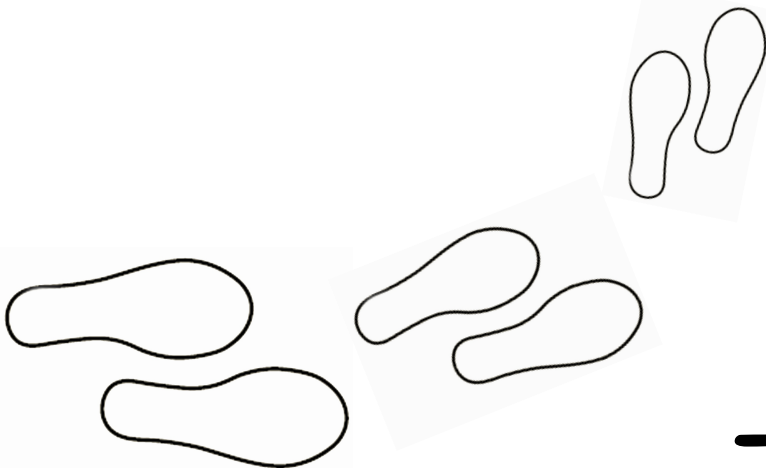
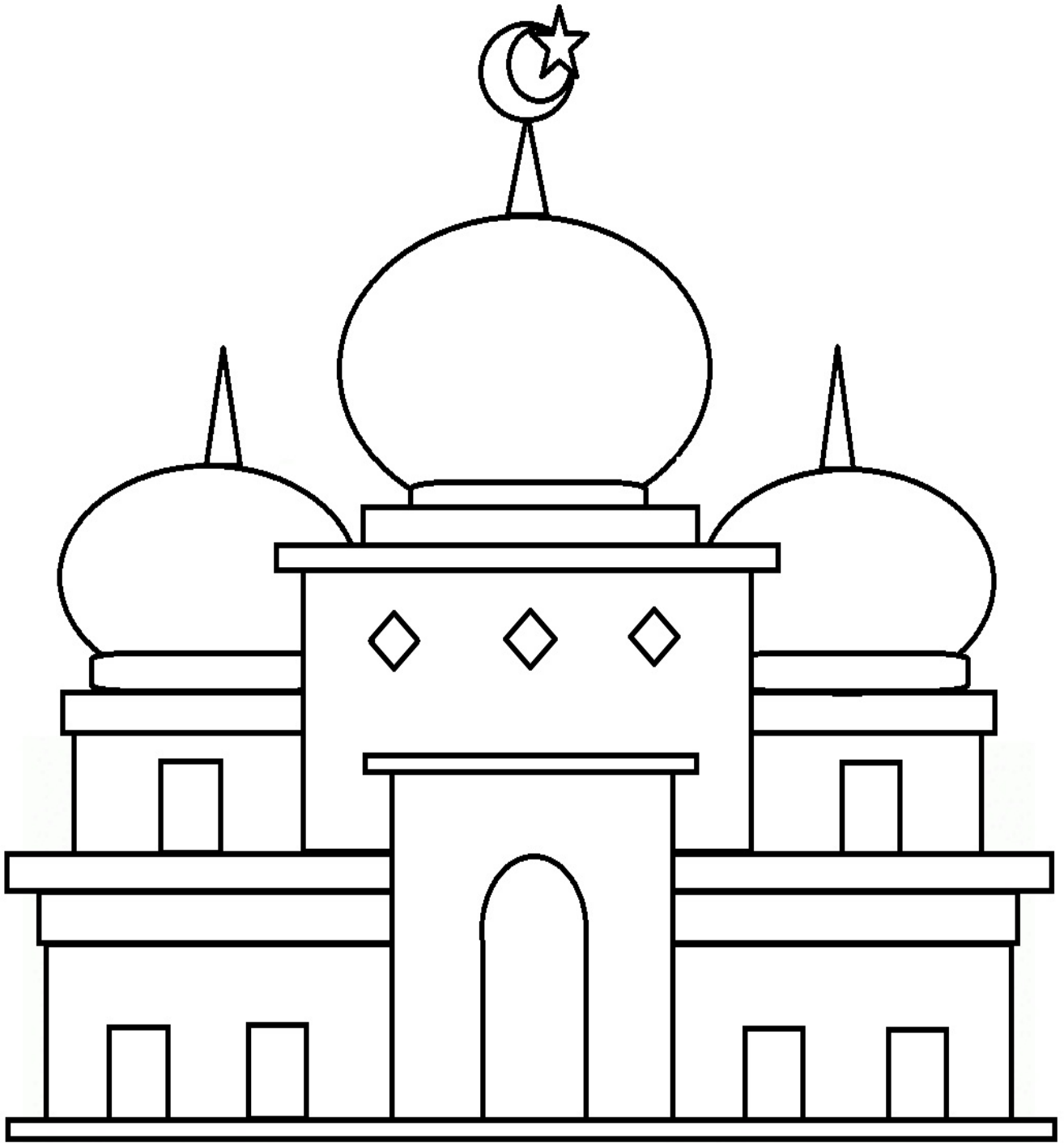

\_ o s q u e

# Find the following words in this 'Good Deed'

Wordsearch:

Reciting Quran

Fasting

Feeding the Poor

Charity

Remembrance of Allah

Night Prayer

Seeking Knowledge

Helping Parents

Z	A	X	R	D	Z	H	K	F	T	K	U	A	G	B	A	E	X	C
Q	F	V	Y	Y	D	H	Z	W	H	L	C	E	A	M	B	W	K	C
V	N	F	A	J	M	A	I	O	G	K	Q	A	U	P	V	U	T	X
V	S	E	G	D	E	L	W	O	N	K	G	N	I	K	E	E	S	P
S	F	Y	C	L	G	L	N	R	M	O	T	E	N	F	A	O	Z	U
T	A	E	F	T	T	A	A	R	E	Y	A	R	P	T	H	G	I	N
N	J	P	W	T	U	F	E	S	W	H	M	Q	N	L	V	F	U	T
E	P	A	S	D	X	O	Y	D	T	D	J	G	O	V	A	V	W	P
R	K	X	A	M	I	E	E	U	H	G	J	Y	U	S	R	A	M	Q
A	K	W	M	I	F	C	M	I	Z	L	Y	O	T	L	G	D	N	P
P	H	G	P	B	C	N	O	D	Y	G	N	I	L	V	M	W	B	N
G	Z	K	T	S	N	A	R	U	Q	G	N	I	T	I	C	E	R	F
N	T	A	I	R	O	R	J	J	M	G	S	O	Y	A	V	V	J	K
I	H	T	M	D	Z	B	G	U		L	B	F	V	X	J	K	L	R
P	X	K	J	G	O	M	I	V	X	Y	T	I	R	A	H	C	Q	Y
L	P	R	O	O	P	E	H	T	G	N	I	D	E	E	F	R	X	R
E	Q	L	H	U	O	M	R	Q	M	W	D	V	G	G	Q	M	F	X
H	L	Y	C	W	Z	E	I	E	Z	K	W	W	G	F	I	W	E	Y
R	Q	I	D	T	D	R	P	B	P	R	E	A	Z	B	L	B	K	S

## Virtues of Fasting:

The Prophet sallallahu alaihi wa sallam said:

Every action performed by the son of Adam can be multiplied in his favour from 10 to 70 times, and Allah the Exalted said: "Except for fasting, because verily it's for Me and I shall reward for it. He (the Muslim) leaves his desires, his food and his drink for My Sake, so the fasting person will have two times of happiness: happiness when he breaks his fast and happiness when he meets his Lord. And the smell that comes from the mouth of the fasting person is better in the sight of Allah than the fragrance of fine perfume."

*(Sahih Bukhari and Muslim)*

Abu Hurayrah reported that the Prophet sallallahu alaihi wa allam said:

"When the month of Ramadhan comes. the doors of Paradise are open, doors of Hell-Fire are closed, and the devils are chained up."

*(Bukhari and Muslim)*

It is the Month of Mercy and Forgiveness and good deeds are multiplied by many.

Fasting has many other benefits such as:

- Taqwa
- Protection from danger
- Patience
- Good health
- Discipline of the soul's desires
- Increase in Obedience (loving good, hating evil)
- Softens the hearts

## Who should fast and who shouldn't?

It is obligatory upon every Muslim to fast the month of Ramadhan with the exception of a few.

Some of these people will either need to make up their fasts or pay an expiation for every day missed.

Allah Subhaanahu wa Ta'ala said:

O you who believe! Observing As-Saum (the fasting) is prescribed for you as it was prescribed for those before you, that you may become Al-Muttaqûn (the pious).

Observing Saum (fasts)] for a fixed number of days, but if any of you is ill or on a journey, the same number (should be made up) from other days. And as for those who can fast with difficulty, (e.g. an old man), they have (a choice either to fast or) to feed a Miskîn (poor person) (for every day). But whoever does good of his own accord, it is better for him. And that you fast, is better for you if only you know.

The month of Ramadân in which was revealed the Qur'ân, a guidance for mankind and clear proofs for the guidance and the criterion (between right and wrong). So whoever of you sights (the crescent on the first night of) the month (of Ramadân i.e. is present at his home), he must observe Saum (fasts) that month, and whoever is ill or on a journey, the same number [of days which one did not observe Saum (fasts) must be made up] from other days. Allâh intends for you ease, and He does not want to make things difficult for you. (He wants that you) must complete the same number (of days), and that you must magnify Allâh [i.e. to say Takbîr (Allâhu-Akbar; Allâh is the Most Great) for having guided you so that you may be grateful to Him.

*(Quran: Surah 2, Ayah 183-185 - Translated by Muhsin Khan)*

**Tick the correct box for the people who are excused from fasting:**

**True      False**

**A Child**

**A Man**

**A Pregnant Woman**

**An Insane Person**

**A Terminally Ill Person**

**A Traveller**

**A Breastfeeding Woman**

**A Teacher**

## How to fast?

1. Make a sincere intention before fajr every day.  
*(Reported by Daraqutni in as-Sunan)*
2. From fajr until maghrib, stay away from the following:  
eating, drinking, desires, evil deeds (lying).

Trace the following:

No Eating

No Drinking

No Lying

No Backbiting

More information on what breaks the fast in this link [here](#).

## Dua for breaking fast:

When we break our fast, the Prophet sallallahu 'alaihi wa sallam said (*reported in Abu Dawud*):

*In Arabic:*

ذهب الظمُّ، وابتلت العروق  
و ثبت الأجر إن شاء الله

*Transliteration:*

*Thahabath-Thama'u Wabtallatil-'Urooqu  
Wa Thabatal-Ajru In Sha' Allaah.*

*In English:*

*"Thirst has gone, the arteries are moist,  
and the reward is sure, if Allaah wills."*

The recommended food to break the fast on is a date (*Abu Dawud*)  
Colour in the dates:

\_ a t e s



The recommended drink to break the fast on is water (*Abu Dawud*)

Colour in the water:

\_ a t e r

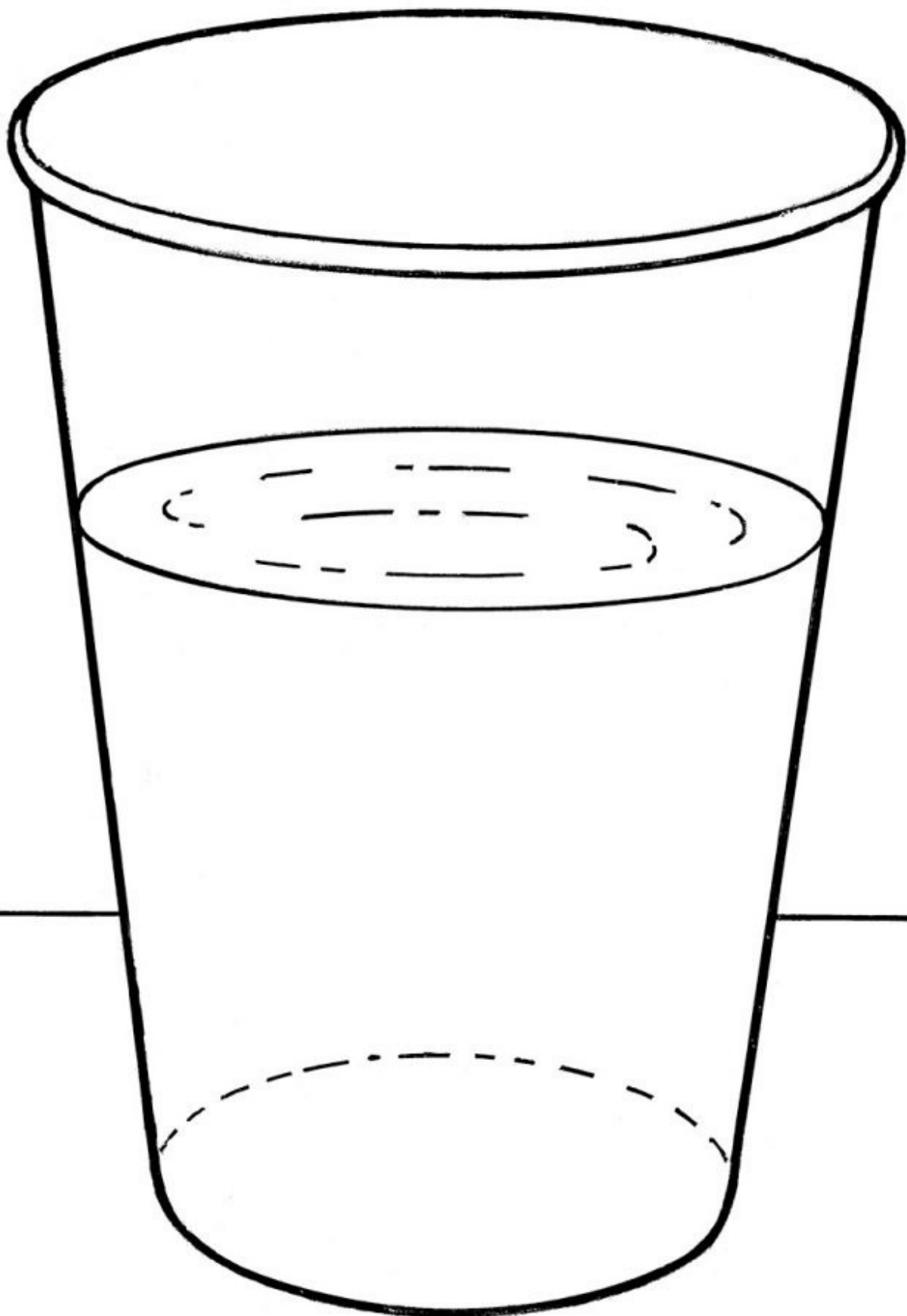

# Eid Day

**Praising Allah**

اللَّهُ أَكْبَرُ اللَّهُ أَكْبَرُ، لَا إِلَهَ إِلَّا اللَّهُ  
اللَّهُ أَكْبَرُ اللَّهُ أَكْبَرُ، وَاللَّهُ الْحَمْدُ

**Ghusl**

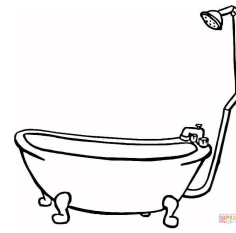

**Wearing Best  
Clothes/Perfume**

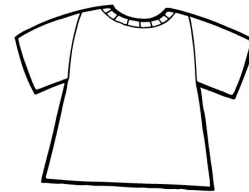

**Eating Odd  
Dates**

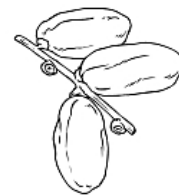

**Walking to Eid  
Prayer**

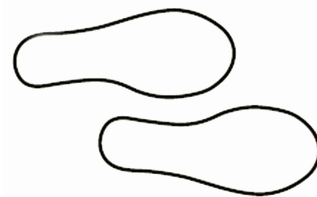

**Zakat ul Fitr**



**Eid Prayer**

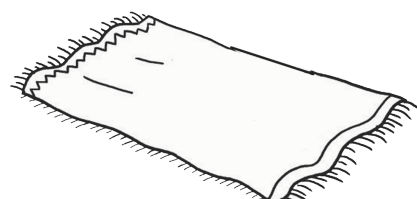

## Tracing Time:

Allan One

Fast Pray

Pray Dua

Charity Mosque

Dates Water

Bath Eid

Allaahu Akbar

Laa ilaaha

il Allaah

Praising Allah on Eid:

اللَّهُ أَكْبَرُ اللَّهُ أَكْبَرُ، لَا إِلَهَ إِلَّا اللَّهُ

اللَّهُ أَكْبَرُ اللَّهُ أَكْبَرُ، وَاللَّهُ الْحَمْدُ

**Allah is the Greatest!**

**Allah is the Greatest!**

**There is no deity worthy of worship  
except for Allah alone!**

**Allah is the Greatest!**

**Allah is the Greatest!**

**And all Praise is to Allah!**

Wear your best clothes

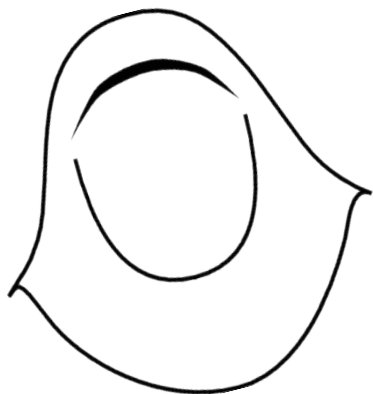

\_\_ o b e

\_ r e s s

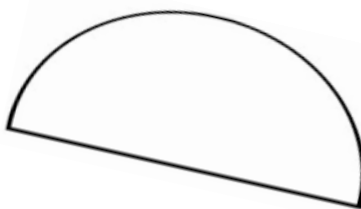
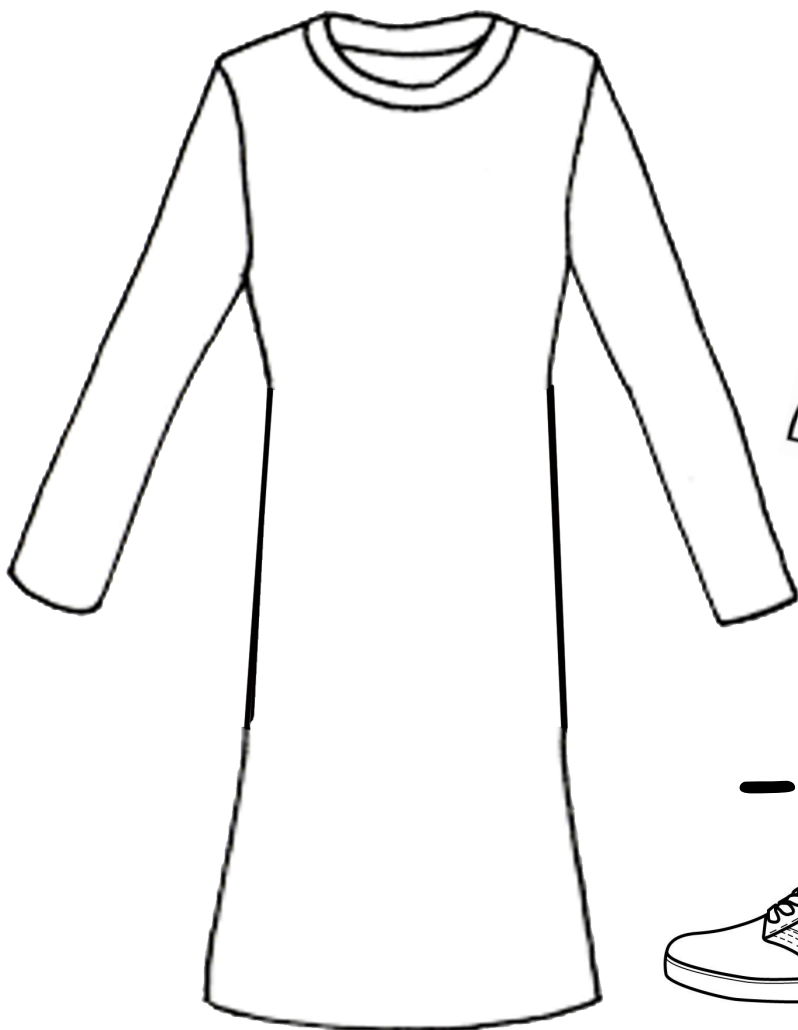

\_\_ o e s



Eat odd dates and walk to the Eid Prayer:

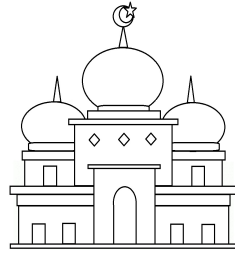

**FINISH**

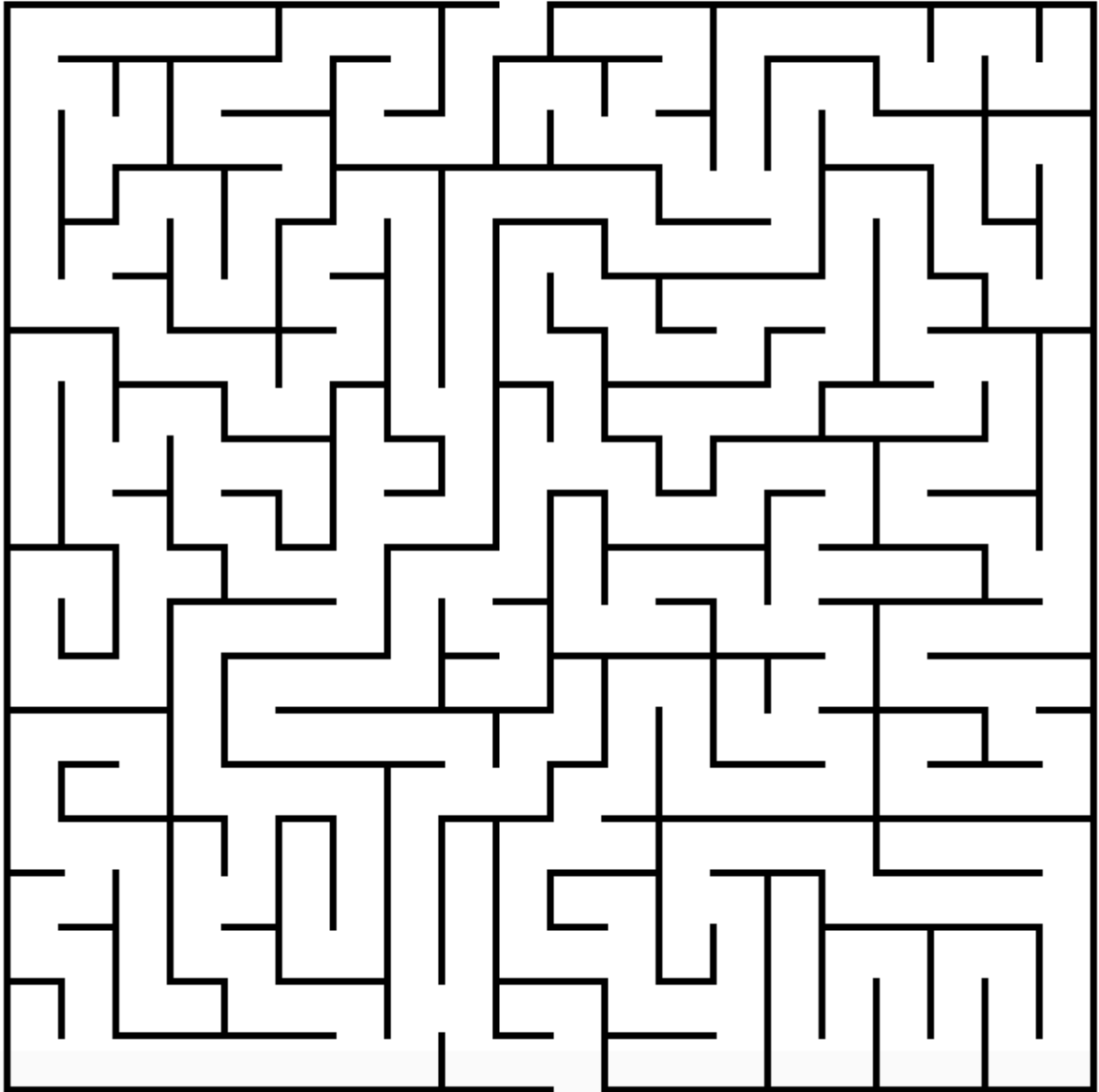

**START**

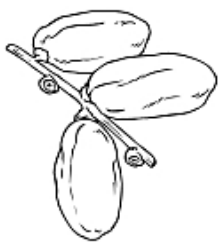

Masjid Puzzle; cut out the puzzle and place them back together correctly:



Give Zakat-ul-Fitr the Pray the Eid Prayer:

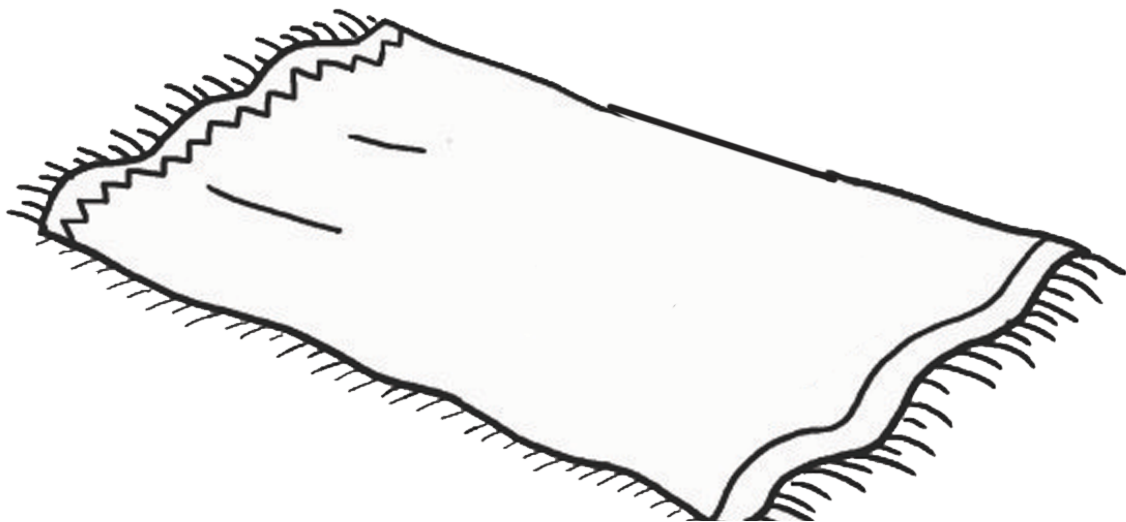
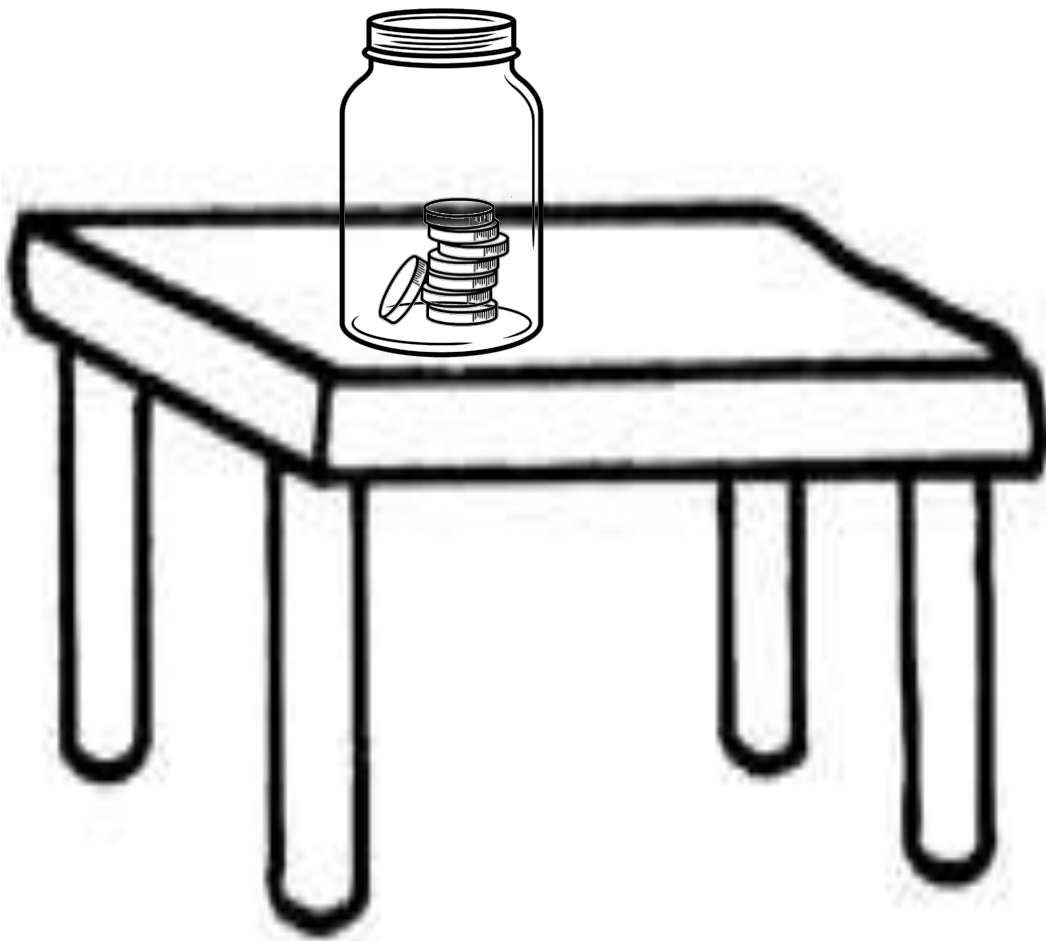

**Quiz Time! Shout out the correct answer (yes or no):**

1. Ramadhan is the ninth Month in the Islam calendar.
2. Muslims fast in the month of Ramadhan.
3. There are 8 Moon phases.
4. Ramadhan is a month of mercy and forgiveness.
5. Helping my parents is a good deed.
6. Lying is a bad deed.
7. I do not eat food when I am fasting.
8. The Quran was revealed in Ramadhan.
9. It's important to give charity every day if we can.
10. The best food to break my fast with is a date.

**If you answered 'yes' to all the points above, then you are correct! Well done!**

**Decorate the Bunting decorations then Cut, Fold and Hang**

Answer the following questions correctly:

1. What are the 5 pillars of Islam?
2. What's the ninth month in the Islamic calendar?
3. How do we verify when Ramadhan begins?
4. How many phases of the moon are there? Can you name them?
5. Name as many good deeds as you can that you can do during the month of Ramadhan.
6. What is the name given to the Night prayer in Ramadhan?
7. What is the dua that we recite on Laylatul-Qadr?
8. What Surah in the Qur'an is 'Laylatul-Qadr' mentioned in?
9. What is the name of the day that Muslims celebrate after the month of Ramadhan?
10. How do we praise Allaah Ta'ala on Eid day?

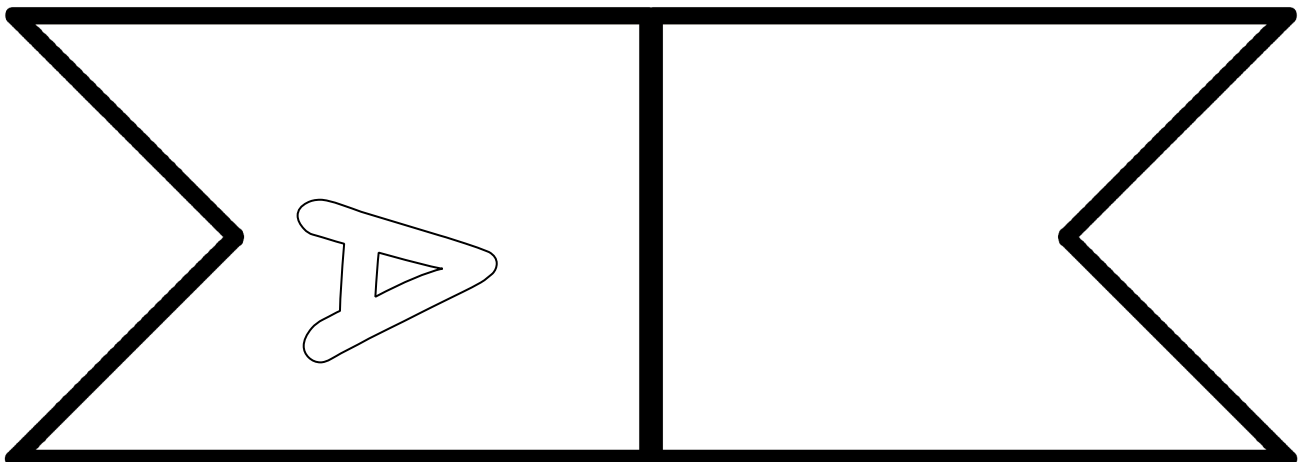
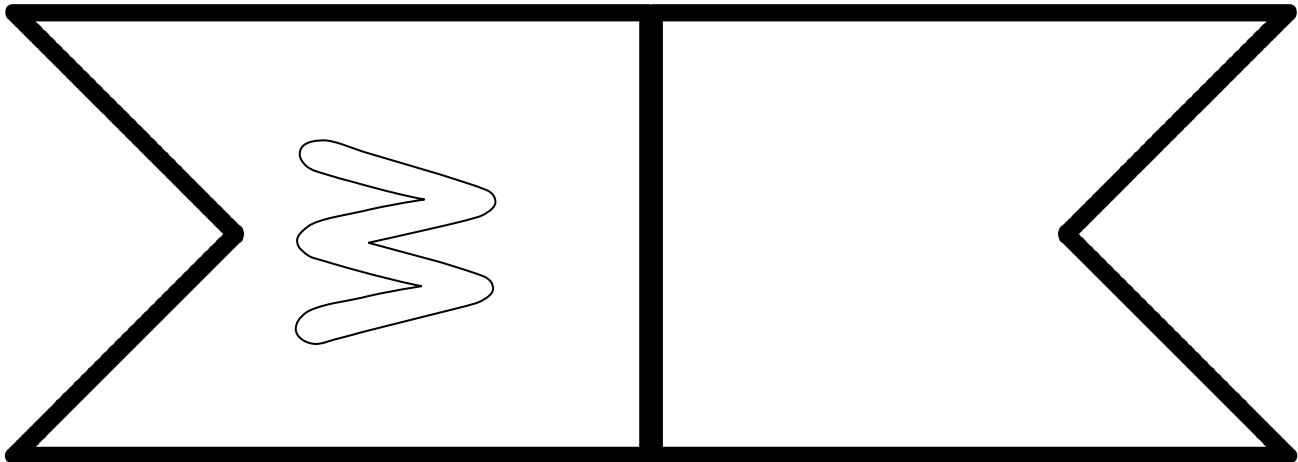
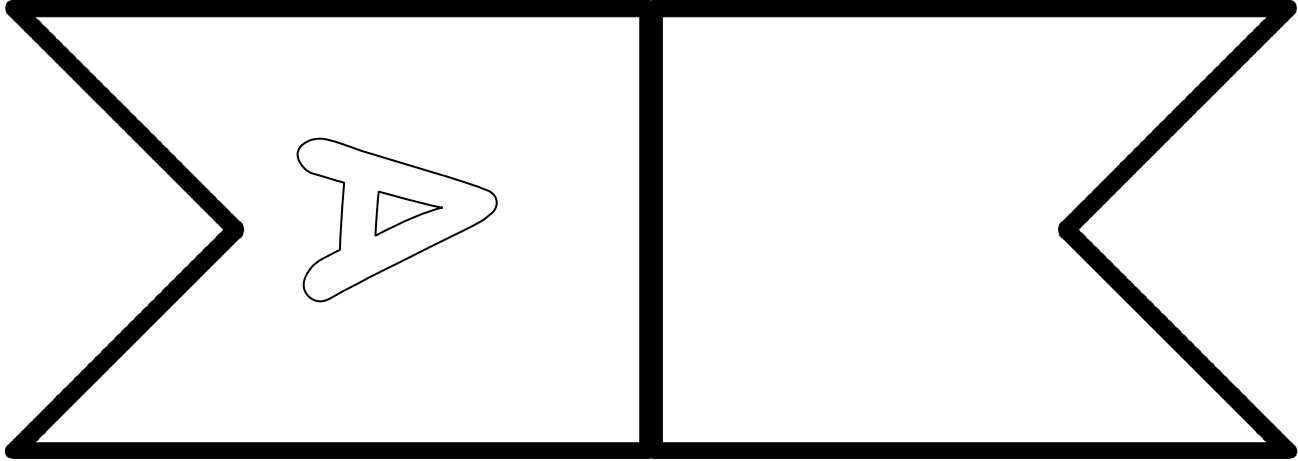
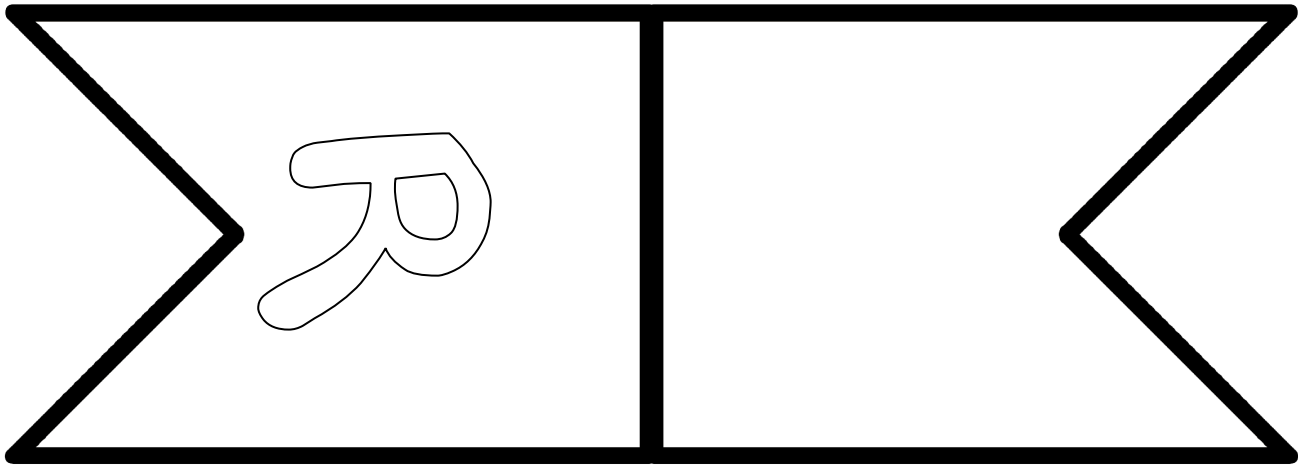

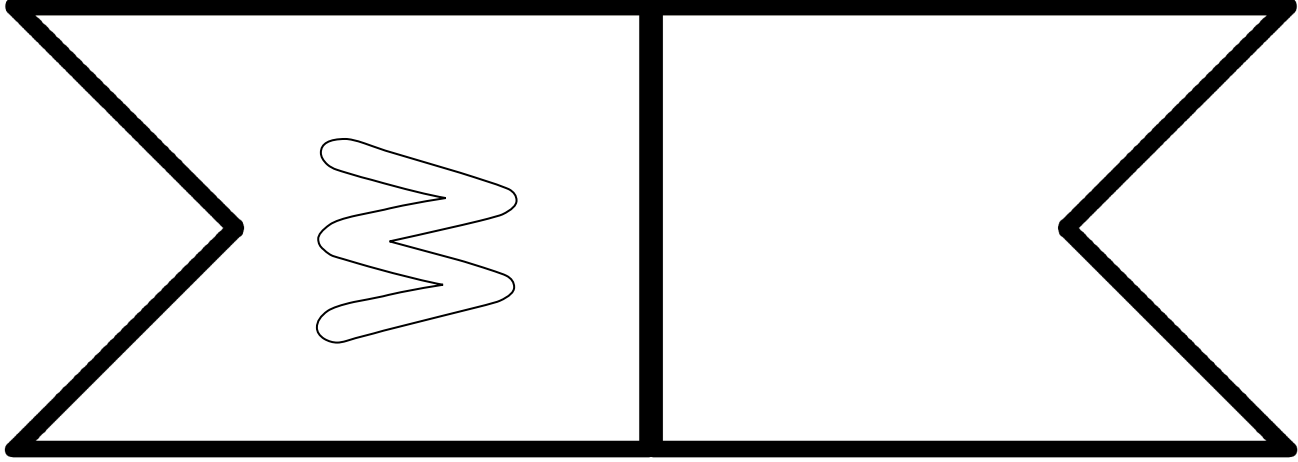
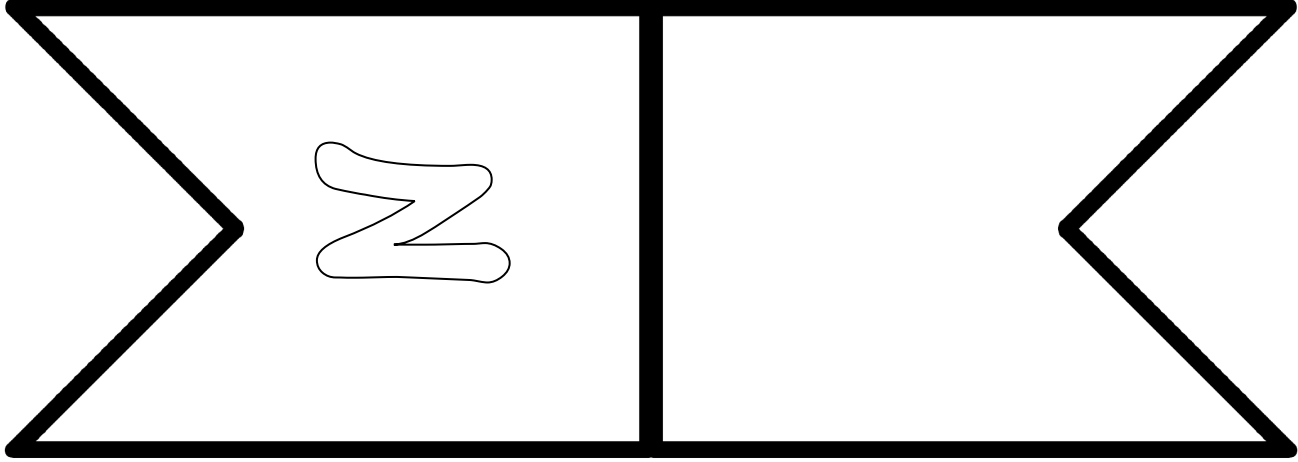
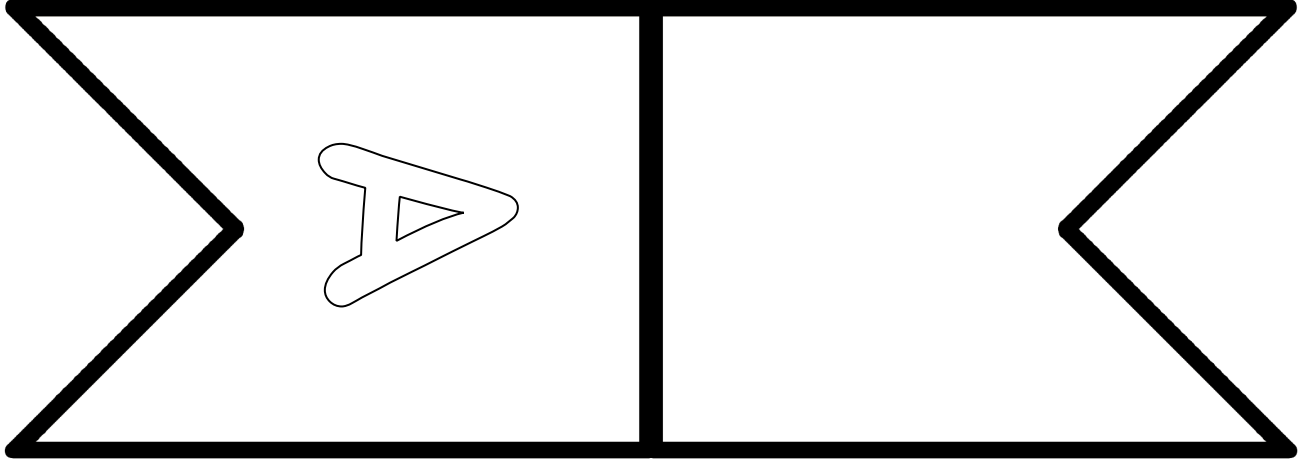
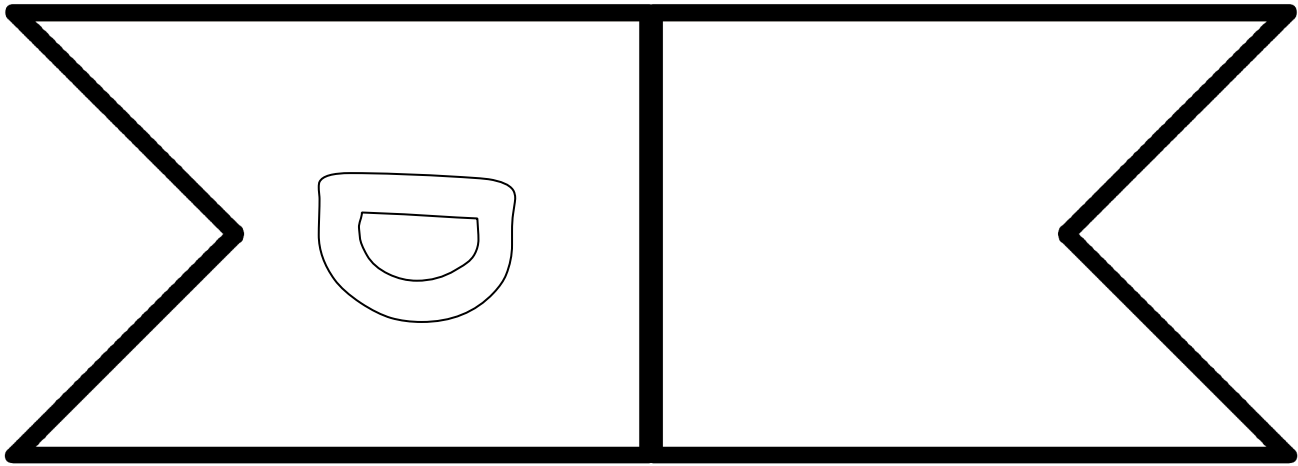

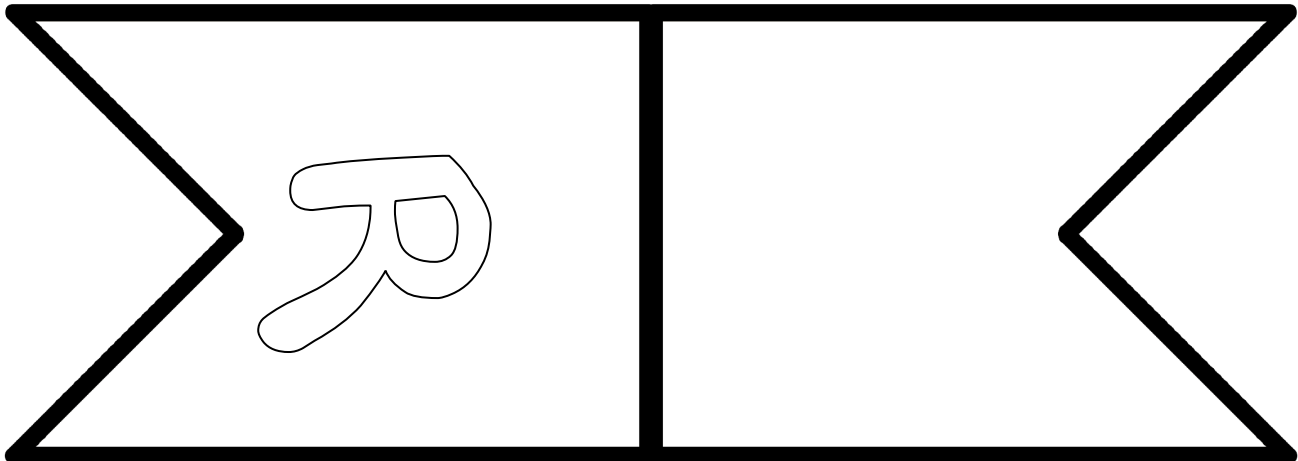
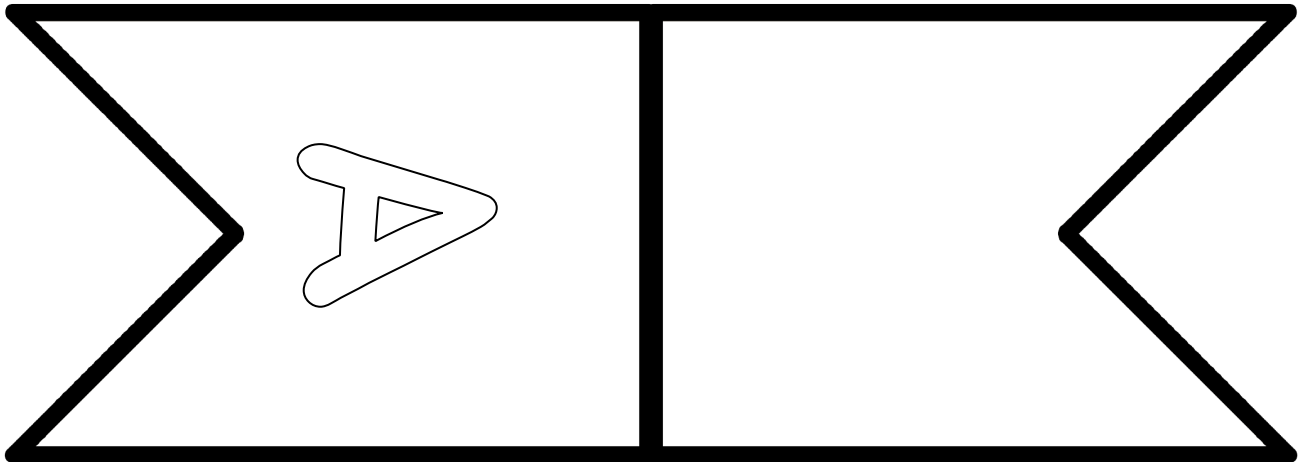
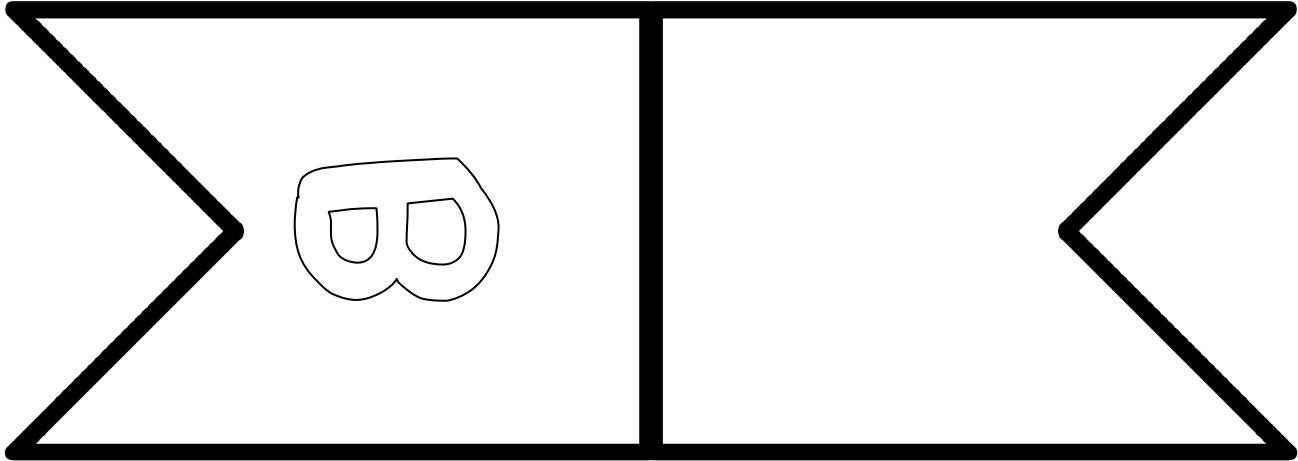
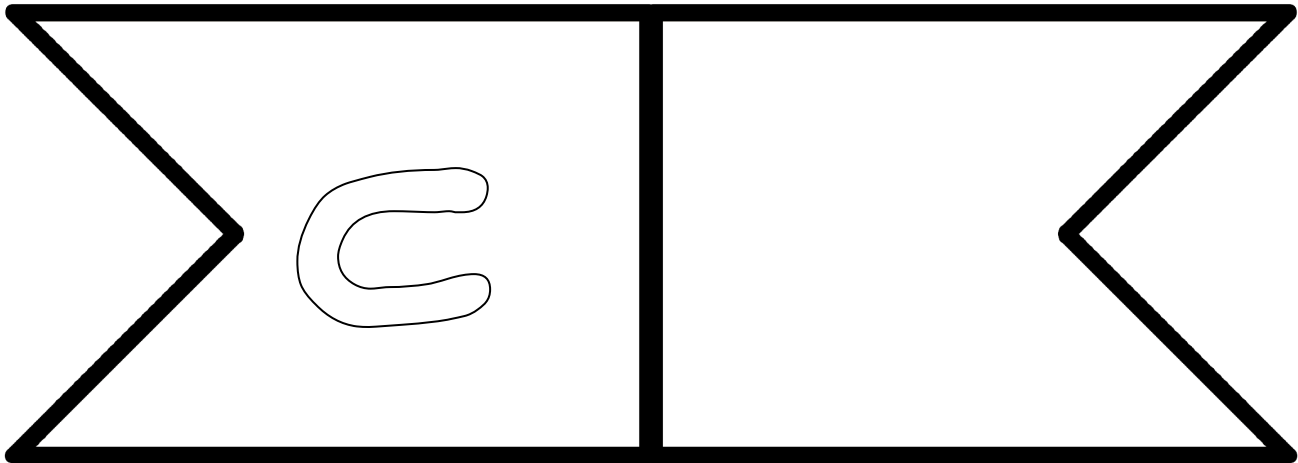

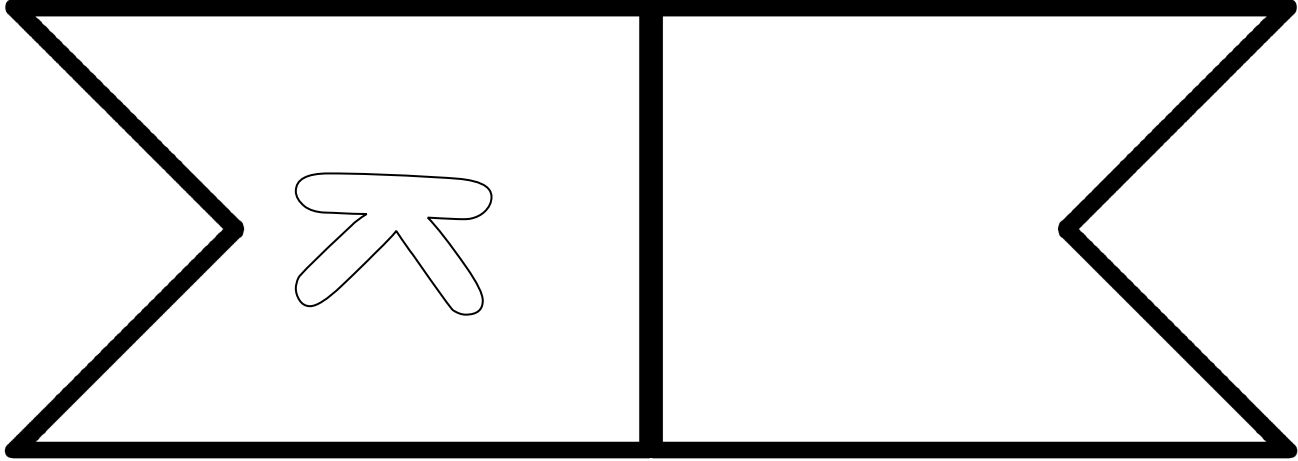
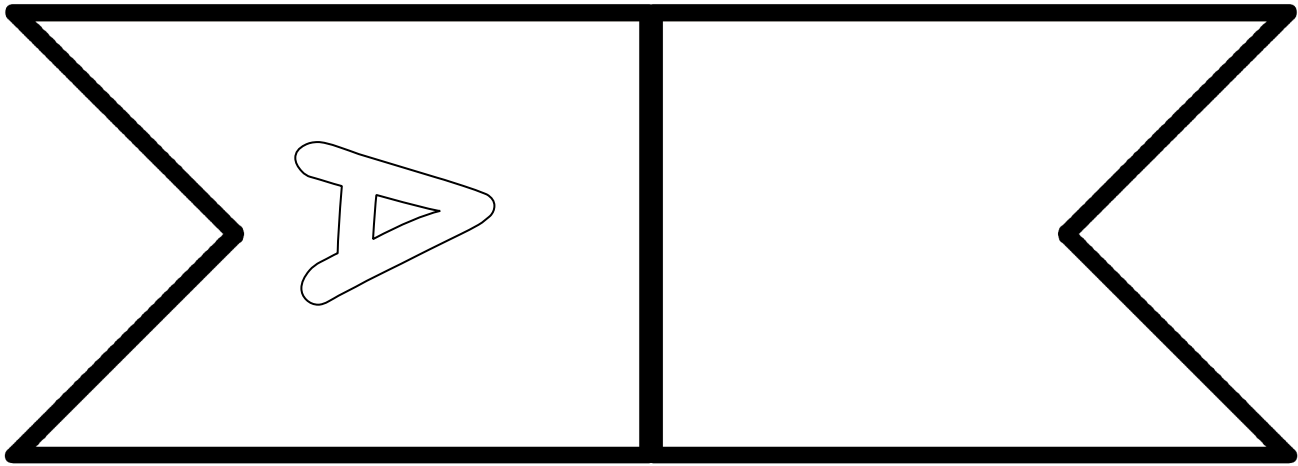

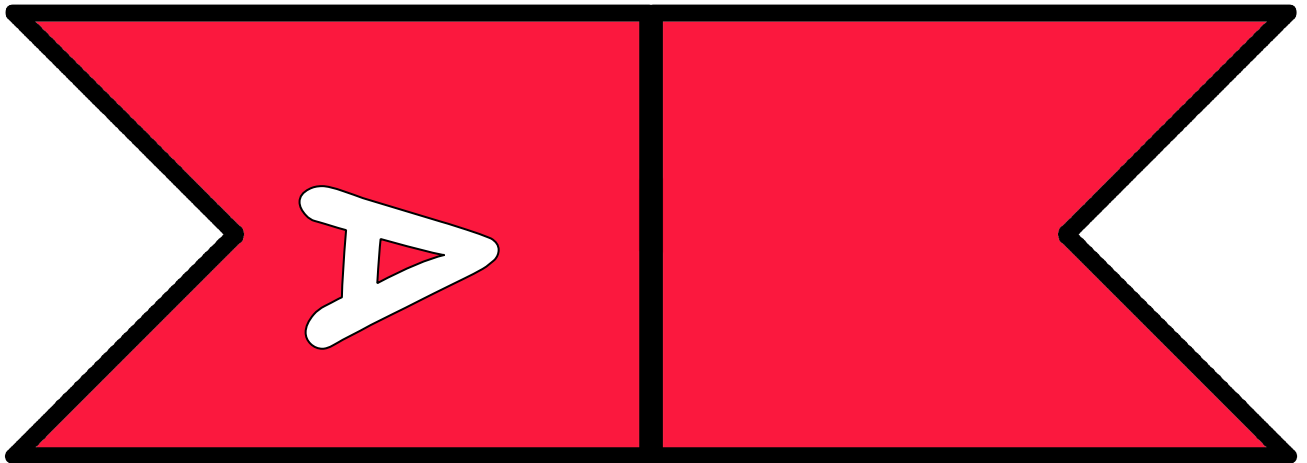
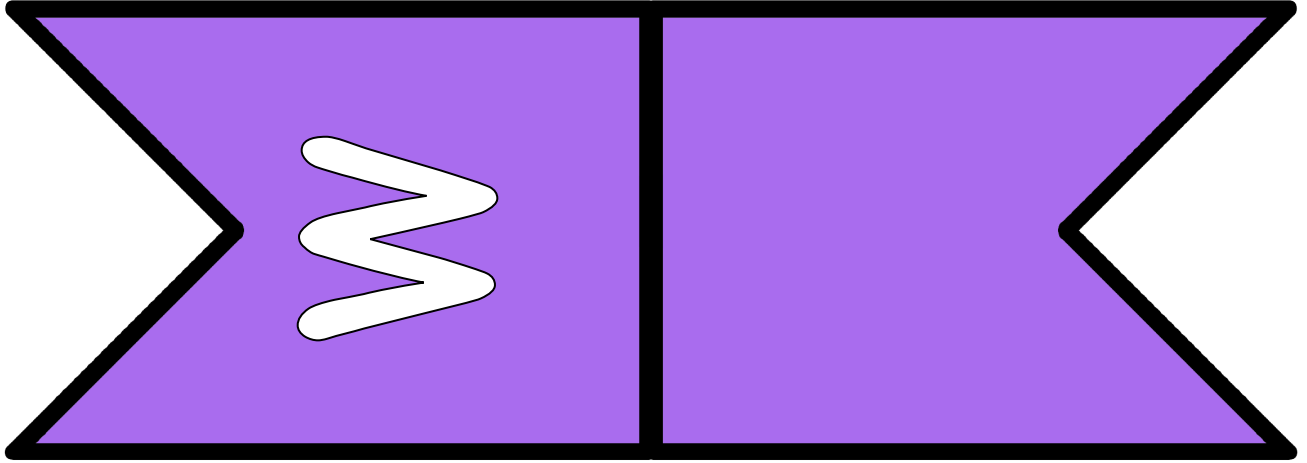
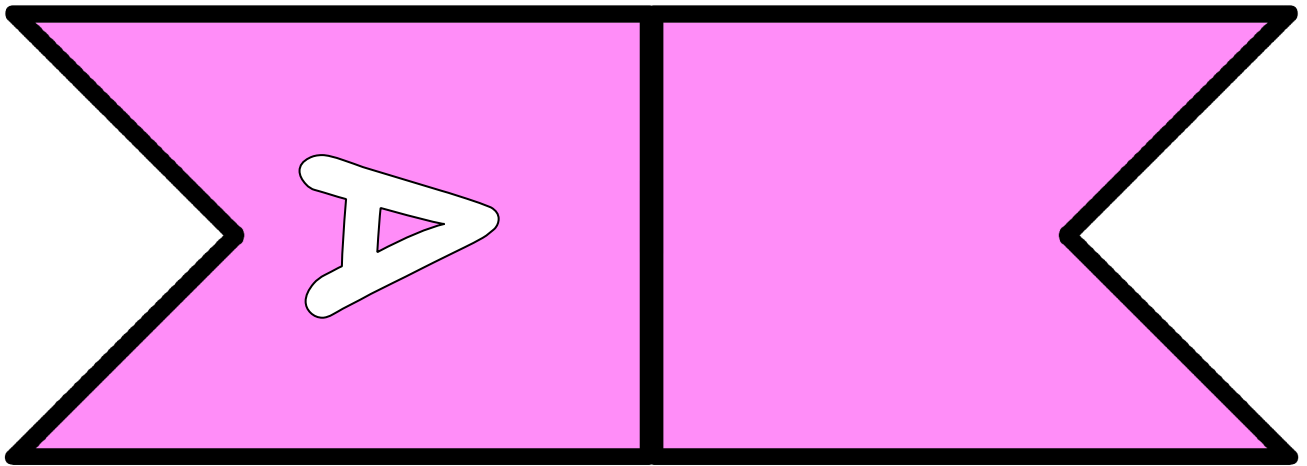
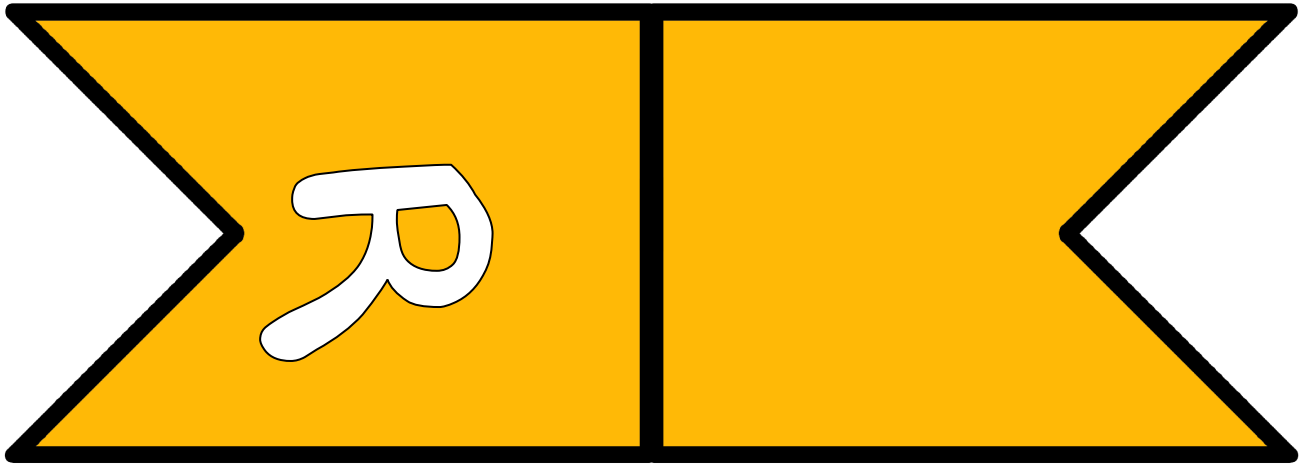

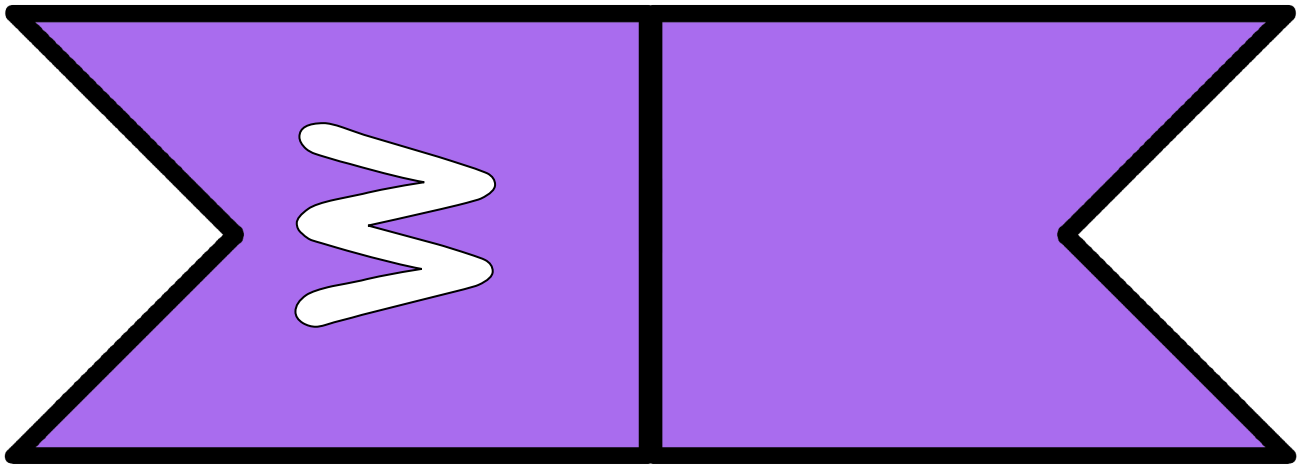
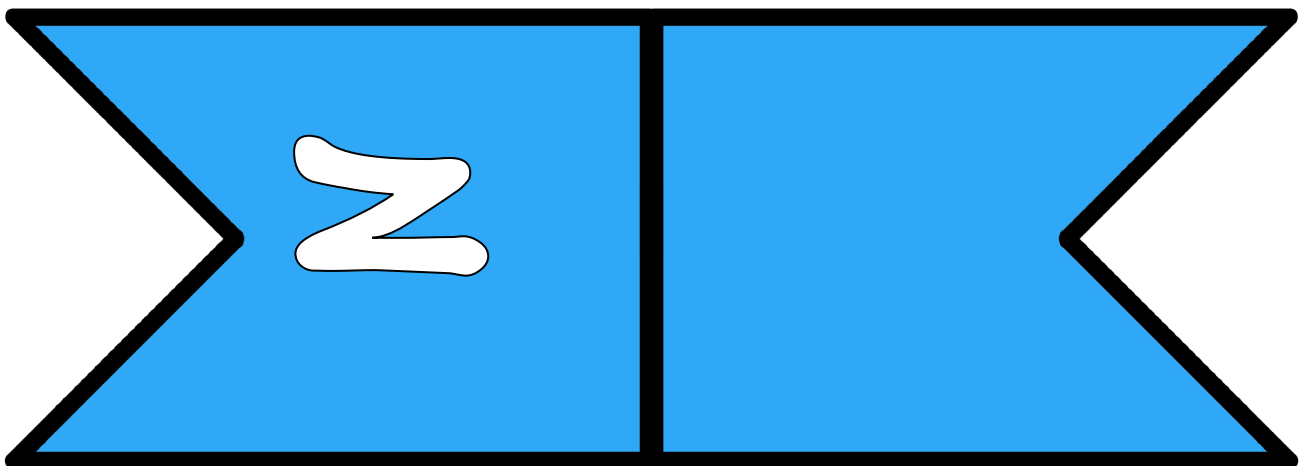
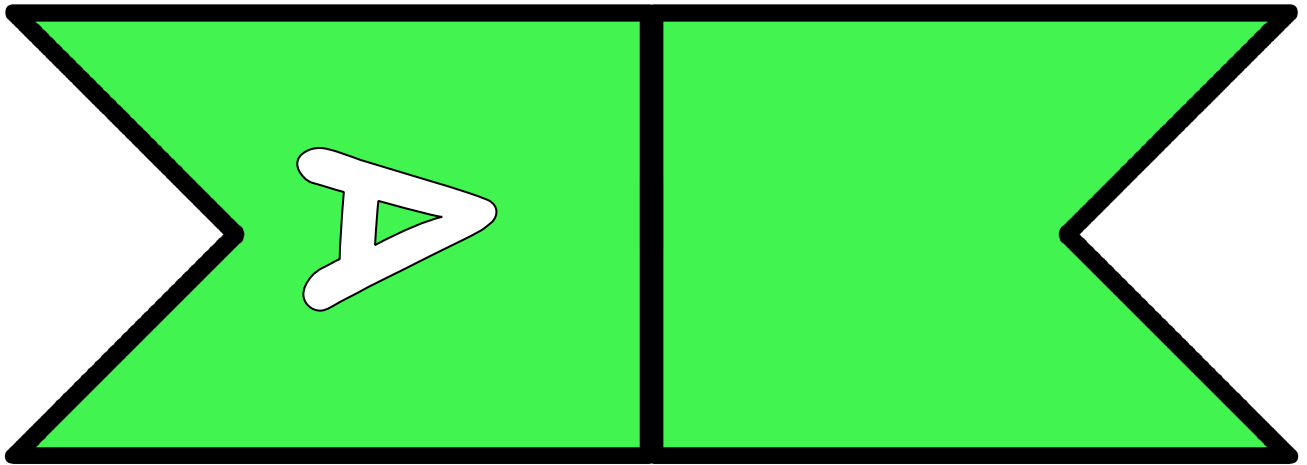
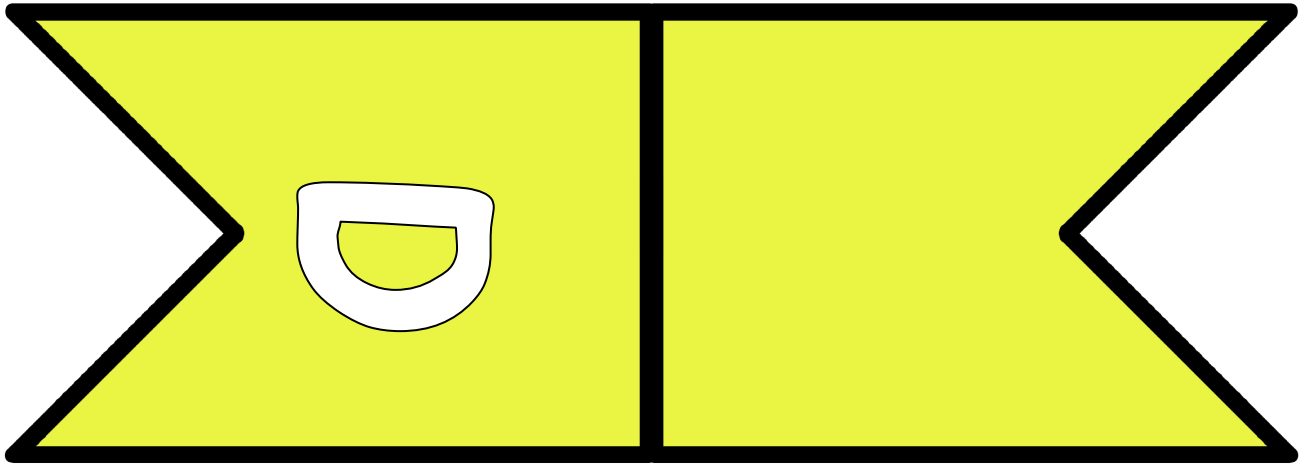

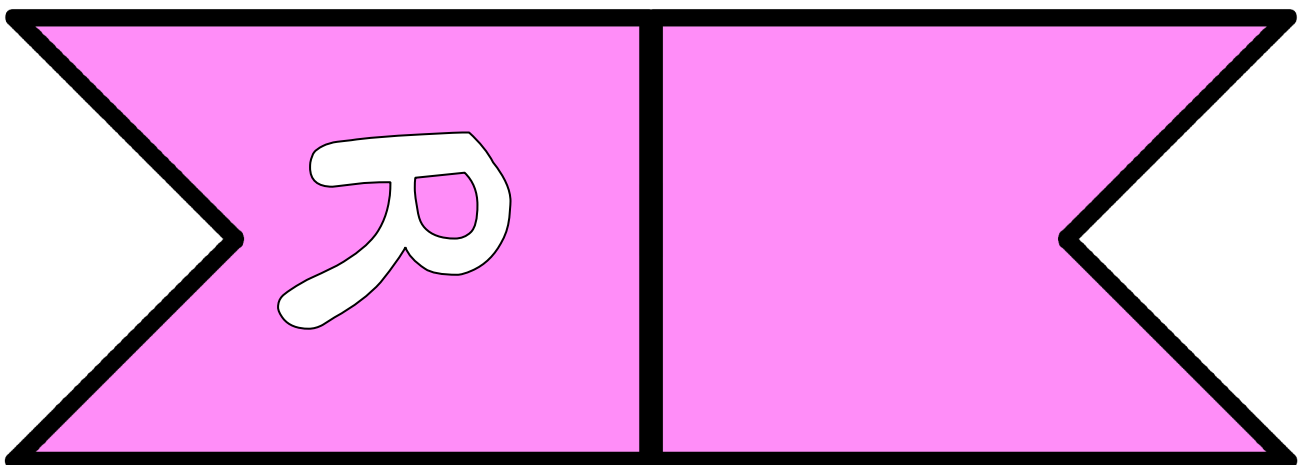
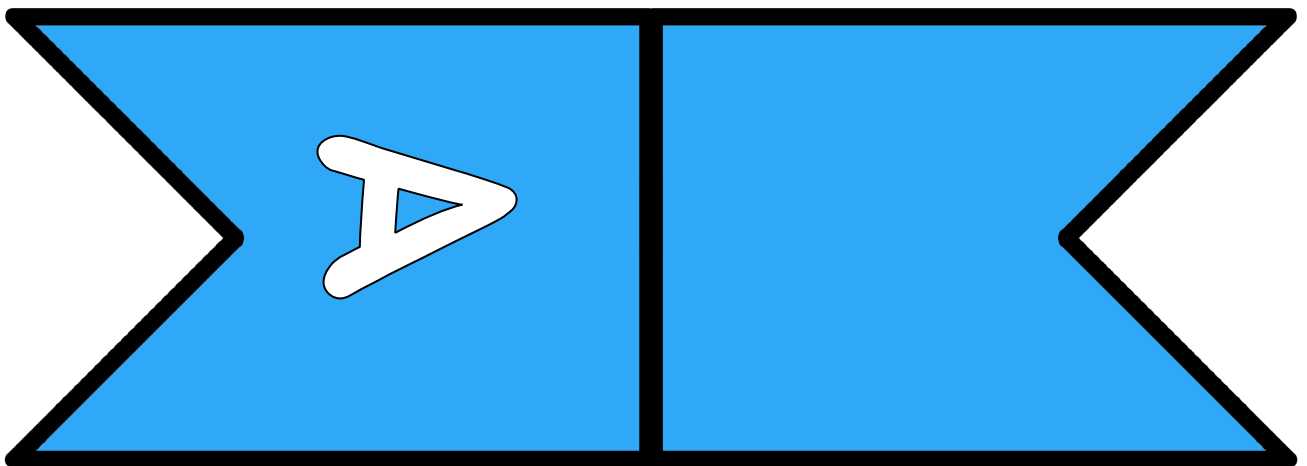
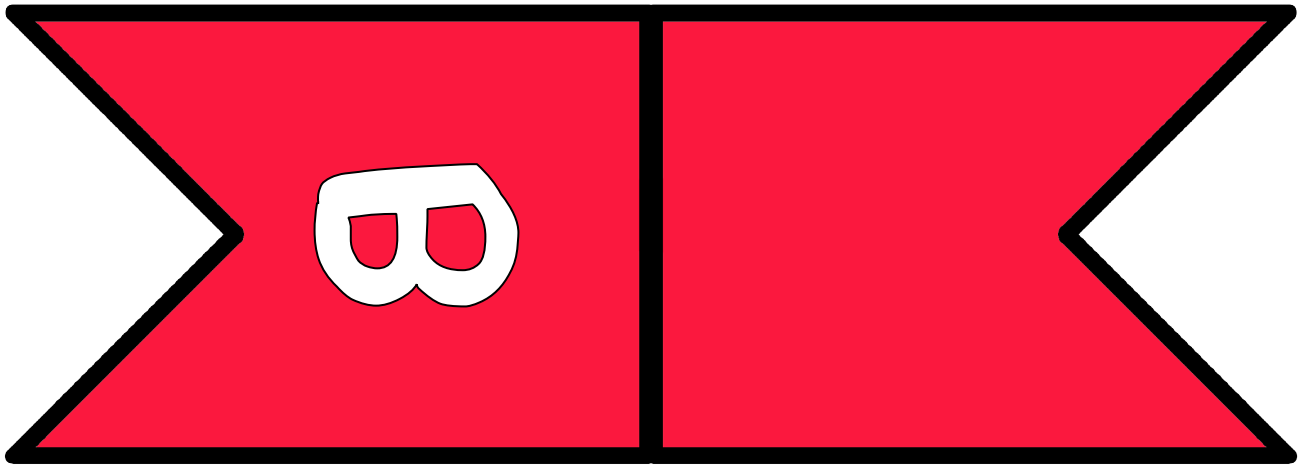
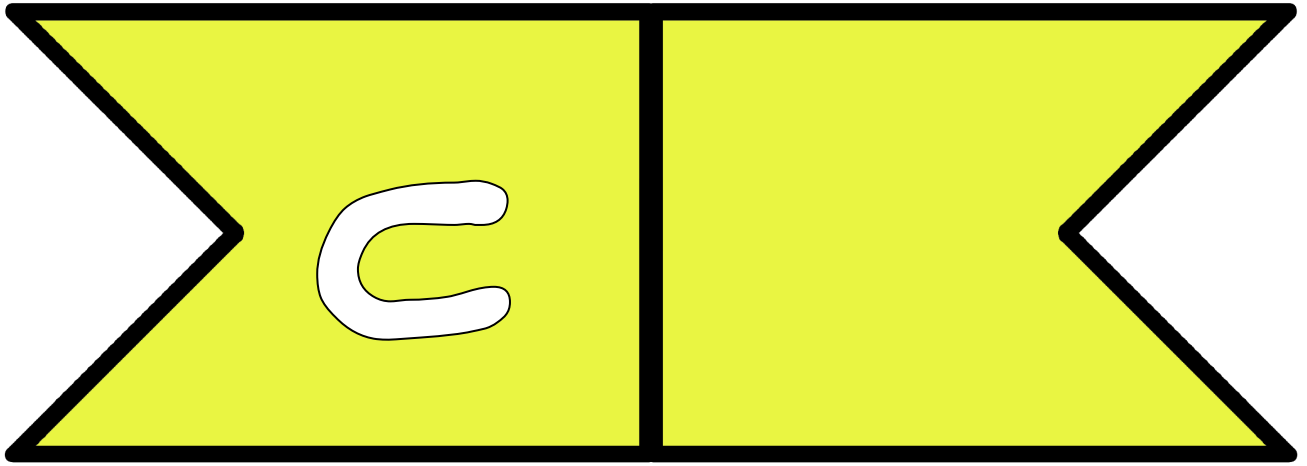

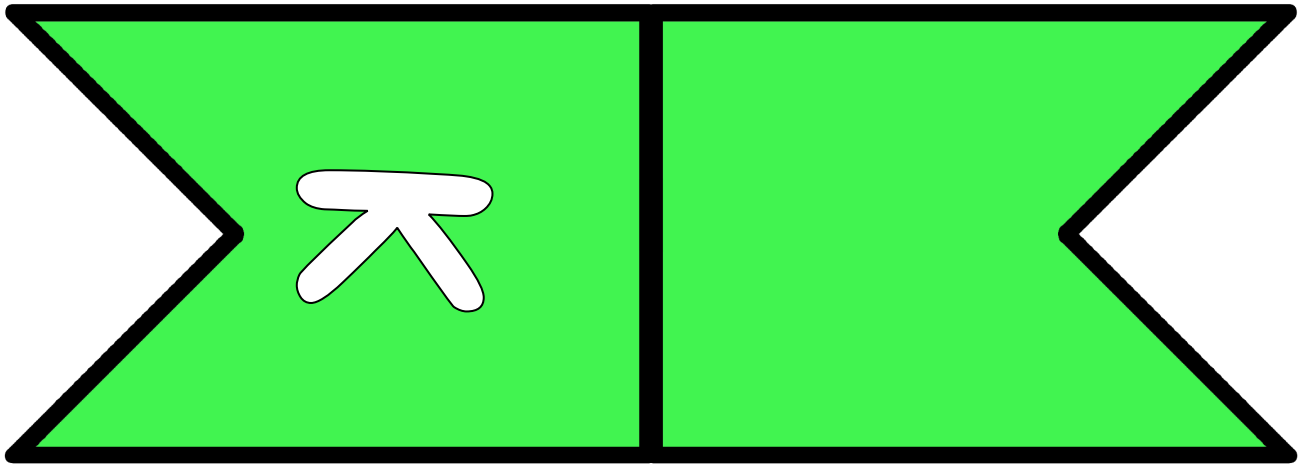
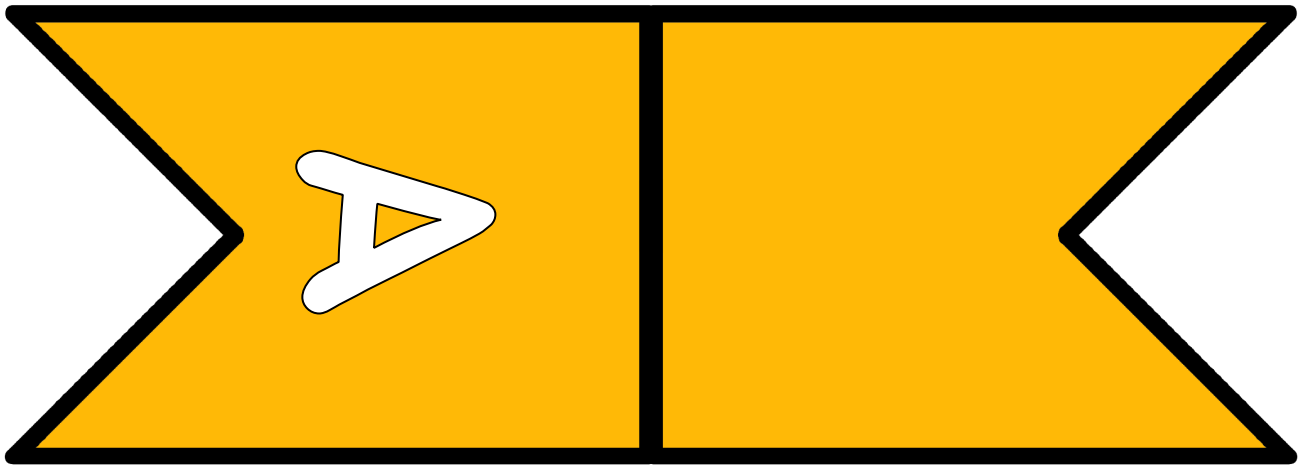

Decorate the Eid Cards then cut out and fold in half:

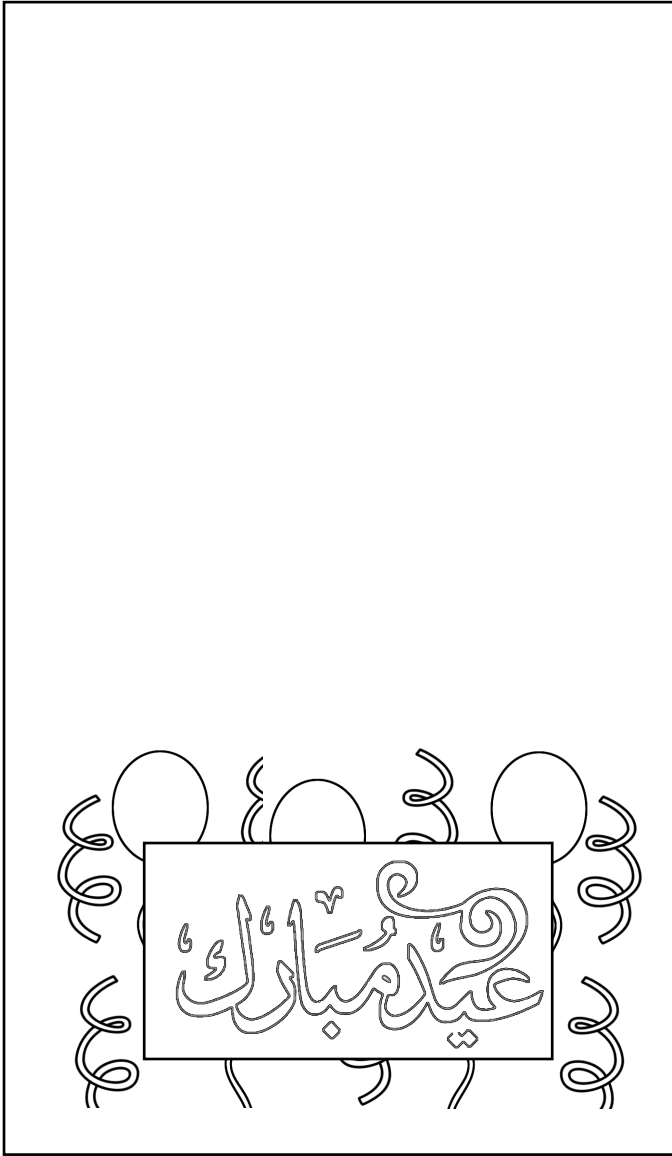

Eid  
mubarak

The text "Eid mubarak" is written in a black, elegant cursive font. The word "Eid" is on the top line, and "mubarak" is on the bottom line, with a long, decorative flourish extending from the end of "mubarak". Behind the text is a black line-art illustration of a mosque with two domes, a minaret, and a crescent moon on top of the minaret.

Eid  
mubarak

This is an identical copy of the calligraphy and mosque illustration described in the first block, positioned in the same relative location within the second rectangular frame.

Eid  
Mubarak

The text 'Eid Mubarak' is written in a large, elegant, black cursive font. The word 'Eid' is on the top line, and 'Mubarak' is on the bottom line. The 'M' in 'Mubarak' is particularly large and features a long, sweeping tail that curves under the rest of the word. Behind the text is a black line-art silhouette of a mosque. It features a large central dome, a smaller dome to the left, and a crescent moon on a tall, slender minaret to the right. The entire design is centered on the page.